

KERRAFRONT. CELLULAR CLADDING

INSTRUCTION FOR INSTALLATION AND USE

SUMMARY

Installation - general rules	4
Cladding boards - detailed description	5
Summary of the rules for implementation	6
Ventilation	7
Dilatation	8
FS-201/ FS-202/ FS-302/ FS-304 Horizontal installation - general rules - ventilation gap = 20 mm	9
FS-201/ FS-301/ FS-202/ FS-302/ FS-304 Horizontal installation - general rules - ventilation gap = 40 mm	10
Trims and accessories	11
Principles of positioning the screws in the fixing holes	12
Horizontal installation - general rules	13
Horizontal installation - system CONNEX	15
Horizontal installation on a timber frame wall	17
Horizontal installation on masonry	19
Installation on masonry wall with metal brackets	20
Vertical installation FS-301/ FS-202/ FS-302/ FS-304	22
Technical data sheet	25

INSTALLATION - GENERAL RULES

1. GENERAL RULES

1.1. Storage

Cellular cladding profiles should be stored inside, on a dry, flat and firm base, without direct contact with the ground. While still in its protective sleeving they should not be stored in places where they may be exposed to direct sunlight.

1.2. Transport (on the pallet)

The profiles should be transported in a horizontal position.

The profiles should be transported in a horizontal position.

1.3. If any visible flaws emerge or irregularities are detected, report them immediately to the seller before installation.

1.4. Installation temperature

The installation should be carried out at ambient temperatures of between 5°C a 30°C. Prior to installation the profiles should be allowed to adjust to atmospheric conditions at the installation site for approx. 24 hrs.

1.5. Dilatation

Keep expansion gaps: the change in size due to significant changes in ambient temperature is a natural and inalienable feature of any item of almost any material, including cellular PVC. Therefore, during the installation always mind the necessity of maintaining expansion gaps between panel ends and the inside pas of finishing trims:

- ca. 8-10 mm for colours: White (WH), Cream (CR), Beige (BE), Claystone (CS), Light Grey (LG), Ivory (IV), Pearl Grey (PG) on boards FS-201, FS-202, FS-302, FS-304
- ca. 15 mm for all other colours.

If the installation takes place in higher ambient temperatures (25-30°C) the clearance should be reduced to ca. 3-4 mm. Bear in mind that with every 10°C of temperature change, total profile length may expand/contract by approx. 0.7 mm per each meter of length.

1.6. Ventilation

Keep ventilation gap behind the cladding panels as specified below (see page 6).

1.7. Working with the profiles

Cellular PVC profiles and accessory trims can be worked using conventional carpentry tools for cutting, drilling and shaping. Saws with fine-toothed blades should be used and power tools should be operated at the same or higher speeds to those normally used for timber work.

1.8. Do not modify the product by machining its surface or coating it with a layer of another material.

1.9. Observe all the rules indicated in the instruction for installations and use.

2. INSTALLATION

2.1. Preparation of the supporting structure

The supporting structure should be made of timber battens or studs, fastened to walls directly or with the use of metal brackets. **IMPORTANT:** all battens should be levelled to reduce any surface irregularities; if necessary, use wedges to level out the irregularities. Timber battens requirements:

- should be made of good quality timber, free of knots, the humidity of 15-18%, suitably treated with preservative
- should be firmly and reliably fixed using screws / wall plugs or other fixings suitable for the type of substrate
- the spacing between intermediate battens/studs directly behind the cladding should not exceed 40 cm centers (max 60 cm for colours: White, Creme, Beige, Claystone, Light Grey, Sand)
- at the corners of a wall and under joint trims use double battening (or battens of double width)
- battens/ studs behind the facade cladding should always provide a proper ventilation gap behind the facade panels:
 - a) min. 20 mm for colours (White, Creme, Beige, Claystone, Light Grey, Sand)
 - b) min. 40 mm for all other colours.

2.2. Installation of finishing trims

Fix the ventilation trims and the starter trims and at the bottom of the area to be clad. **IMPORTANT:** in order for the cladding to be installed properly in a level fashion, the starter trims at the bottom of the walls **MUST** be level. Keep the ends of starting trims at least 5 mm apart to allow for expansion.

Fix the inner parts of perimeter trims over supporting battens; fix vertical trims using specified fixings at recommended intervals of 30 cm. Do not fix outer parts of the 2-part trims before panels are installed. The outer parts should be put aside and protected from damage until ready for use.

2.3. Installation of cladding boards

Plan out the places of panel butt-joints on the area to be clad. If a center joint trim is to be used, it should be fixed on supporting batten at least of the same width (use 2 battens if necessary). If joint covers are to be used to butt-join adjacent panels, they should be staggered to make a regular pattern on a wall. Cut the panels to required lengths based on that planning.

Mount the first cladding board on the starter trim, ensuring that the back leg of the panel is engaged in the trim slot. Board fixing should commence at the center of its length to the batten through the nailing slot or groove at the top edge, then work progressively outwards. Fasteners should always be placed in the middle of the length of a slot. If a nail slot falls outside a supporting batten, use a batten offcut, fasten it to the substrate under the required slot and screw the panel to the timber offcut with a fastener. Always make sure that each end of a board is screwed/nailed to a batten.

IMPORTANT: In wooden decors panels are not identical - they can differ significantly from each other. Before installation, you need to open a few different packages and think about how to arrange them on the wall for the desired effect.

IMPORTANT: Never drive the head of the fastener tight into the panel surface, as it may hinder any thermal movement. Keep a small clearance between the fastener heads and panel surface so that each panel can be moved horizontally left/right after all its fasteners have been screwed to the battens.

IMPORTANT: Maintain expansion gaps between panel ends and the inside parts of the finishing trims, as indicated above. The gaps will subsequently be concealed by the outer parts of finishing trims.

All joint covers and vertical trims must be fixed on supporting battens. Joint covers should be installed tight to the panel ends as work proceeds - their spacing lugs will automatically provide proper clearance between adjacent panel lengths. Joint covers cannot be placed directly one over another. Joint covers forming a vertical line should be separated from each other by at least 2 courses of cladding panels. Provide packing behind any panels cut along the top edge; panel off-cuts may be suitable for that purpose.

2.4. Insert the top parts of all 2-part trims to finish the installation

No fixings are required.

3. INFORMATION FOR USAGE

During the use, possible colour changes caused by sunlight, in moderate climate, with air temperatures not exceeding 40°C, at a height of up to 1800 m above sea level, may have a homogeneous nature not exceeding the 3rd degree in the grey scale (EN 20105-A02).

4. CLEANING AND MAINTENANCE

Cellular cladding profiles are finished, practically maintenance-free products. In order to preserve the esthetics we recommend to clean it at least once a year depending on the degree of soiling. Clean the panels and trims using a domestic detergent solution with a temperature not exceeding 40°C. Do not use solvents or similar aggressive and caustic fluids. Wash the surface with clean water after cleaning.

CLADDING BOARDS - DETAILED DESCRIPTION

FS-302

Double board: 6m, 2,95 m CONNEX

Covering width: 332 mm
Installation: horizontal/ vertical

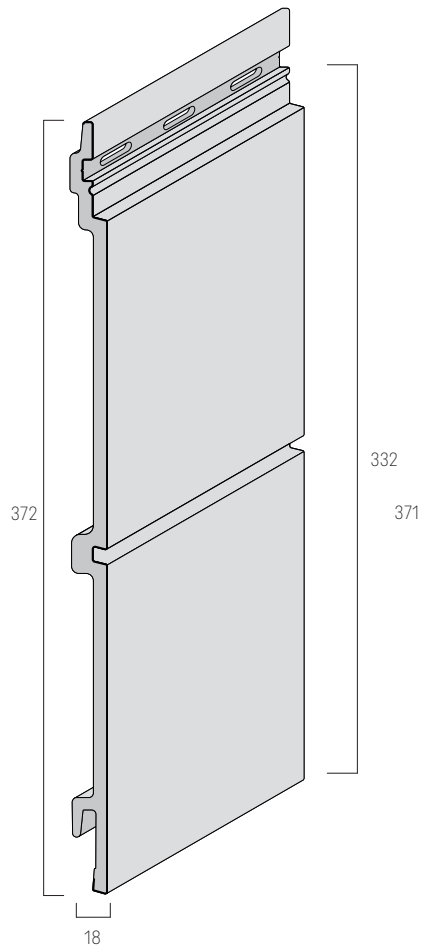

FS-202

Double board: 6m, 2,95 m CONNEX

Covering width: 332 mm
Installation: horizontal/ vertical

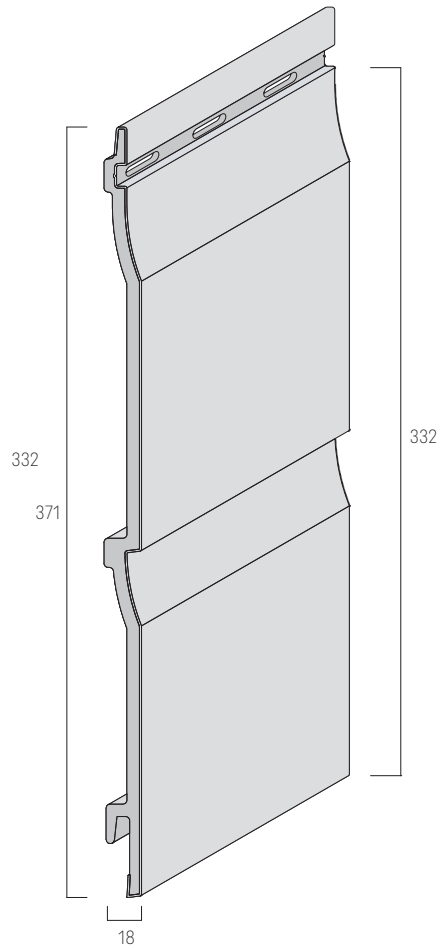

FS-201

Single board: 6m, 2,95 m CONNEX

Covering width: 180 mm
Installation: horizontal

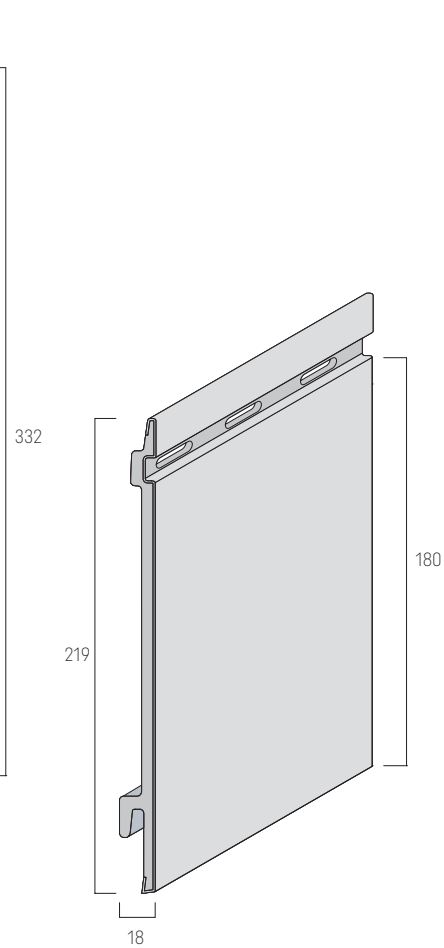

FS-301

Single board: 6 m, 2,95 m CONNEX

Covering width: 320 mm
Installation: horizontal/ vertical

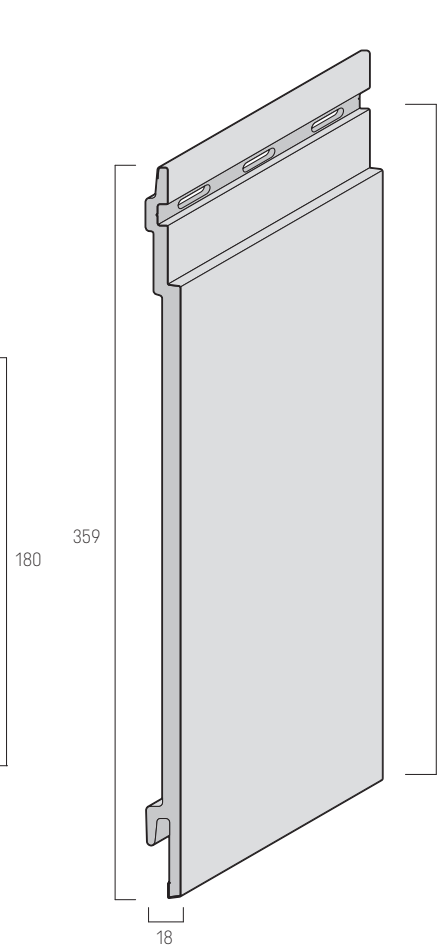

FS-304

Fourfold board: 6m, 2,95 m CONNEX

Covering width: 332 mm
Installation: horizontal/ vertical

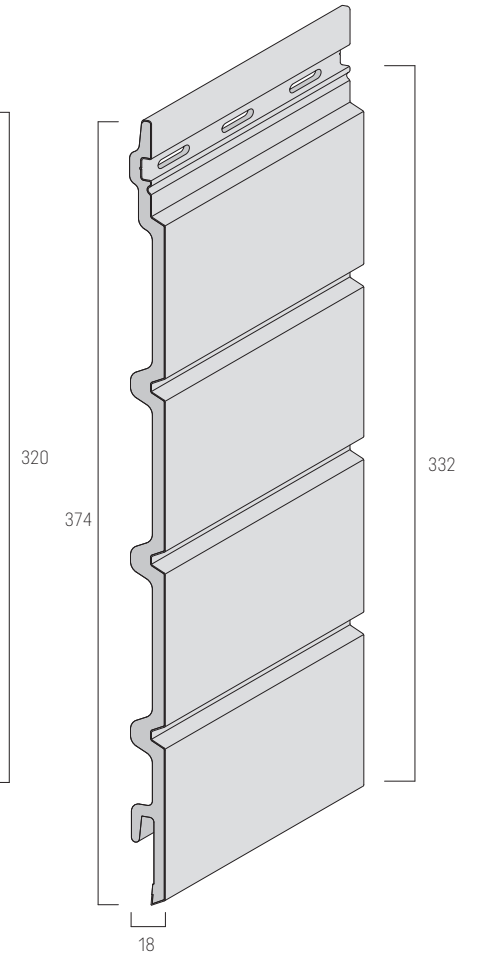

SUMMARY OF THE RULES FOR IMPLEMENTATION

COLLECTION	TYPE OF THE BOARD	TYPE/ LENGHT	COLOUR	VENTILATION	SPACE BETWEEN THE BATTENS
MODERN WOOD	Double board	FS-302 6 m	White (WH), Ivory (IV), Claystone (CS), Beige (BE), Pearl Grey (PG) Quartz Grey (QG), Anthracite (AN)	2 cm 4 cm	40 cm (60 cm possible) 40 cm
		FS-302 CONNEX 2,95 m	White (WH), Ivory (IV), Claystone (CS), Beige (BE), Pearl Grey (PG) Quartz Grey (QG), Anthracite (AN)	2 cm 4 cm	40 cm
	Fourfold board	FS-304 6 m	White (WH), Ivory (IV), Claystone (CS), Beige (BE), Pearl Grey (PG) Quartz Grey (QG), Anthracite (AN)	2 cm 4 cm	40 cm (60 cm possible) 40 cm
		FS-304 CONNEX 2,95 m	White (WH), Ivory (IV), Claystone (CS), Beige (BE), Pearl Grey (PG) Quartz Grey (QG), Anthracite (AN)	2 cm 4 cm	40 cm
TREND	Single board	FS-301 6 m	Ivory (IV), Ivory Stone (IVS), Mastic (MA), Mastic Stone (MAS), Pearl Grey (PG) Pearl Grey Stone (GPS), Anthracite (AN), Anthracite Stone (ANS)	4 cm	40 cm
		FS-301 CONNEX 2,95 m			
CLASSIC	Single board	FS-201 6 m	White (WH), Cream (CR), Beige (BE), Claystone (CS), Light Grey (LG) Grey (GR), Quartz Grey (QG), Olive (OL), Anthracite (AN)	2 cm 4 cm	40 cm (60 cm possible) 40 cm
		FS-201 CONNEX 2,96 m	White (WH), Cream (CR), Beige (BE), Claystone (CS), Light Grey (LG) Grey (GR), Quartz Grey (QG), Olive (OL), Anthracite (AN)	2 cm 4 cm	40 cm
	Double board	FS-202 6 m	White (WH), Cream (CR), Beige (BE), Claystone (CS), Light Grey (LG) Grey (GR), Quartz Grey (QG), Olive (OL), Anthracite (AN)	2 cm 4 cm	40 cm (60 cm possible) 40 cm
		FS-202 CONNEX 2,95 m	White (WH), Cream (CR), Beige (BE), Claystone (CS), Light Grey (LG) Grey (GR), Quartz Grey (QG), Olive (OL), Anthracite (AN)	2 cm 4 cm	40 cm (60 cm possible) 40 cm
RETRO	Double board	FS-202 6 m	Cream (CR), Beige (BE), Sand (SA) Blue (BL)	2 cm 4 cm	40 cm (60 cm possible) 40 cm
RUSTIC	Single board	FS-201 6 m	Tawny (TA), Aqua Blue (AB), Sky Grey (SKG)	4 cm	40 cm
		FS-201 CONNEX 2,95 m			
	Double board	FS-202 6 m			
		FS-202 CONNEX 2,95 m			
WOOD DESIGN	Single board	FS-201 6 m	Golden Oak (GO), Silvergrey (SG), Graphite (GP)	4 cm	40 cm
		FS-201 CONNEX 2,95 m			
WOOD EFFECT	Fourfold board	FS-304 6 m	Malt Oak (MO), Concrete Oak (CO), Alpine Oak (AO), Caramel Oak (CAO)	4 cm	40 cm
		FS-304 CONNEX 2,95 m			
	Single board	FS-201 6 m			
		FS-201 CONNEX 2,95 m			

! VENTILATION

The principle of ventilated cladding requires that the air path must not be obstructed both at the top and bottom of the clad area.

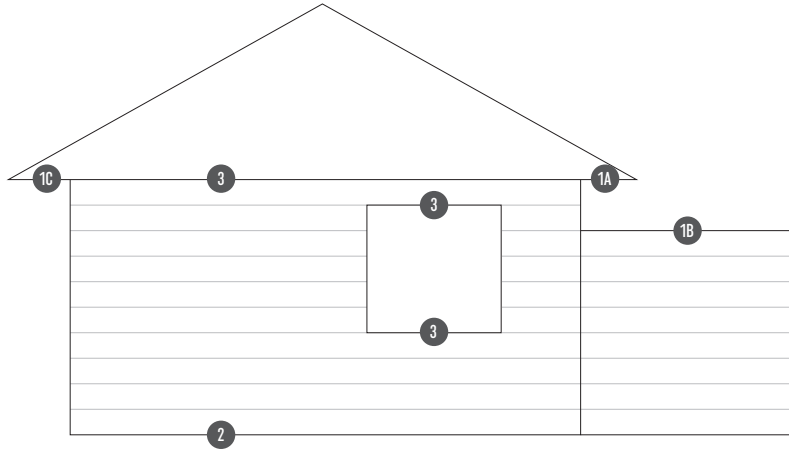

2 Bottom ventilation

3 Window joinery

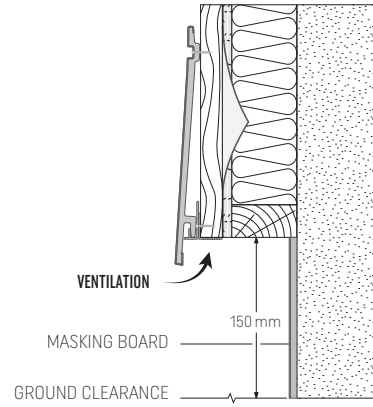

Door / window head

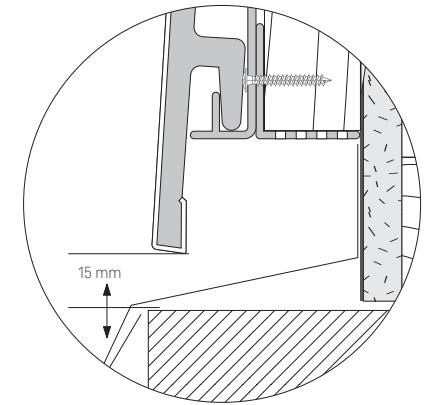

1 Top ventilation

1A Ventilation under eaves

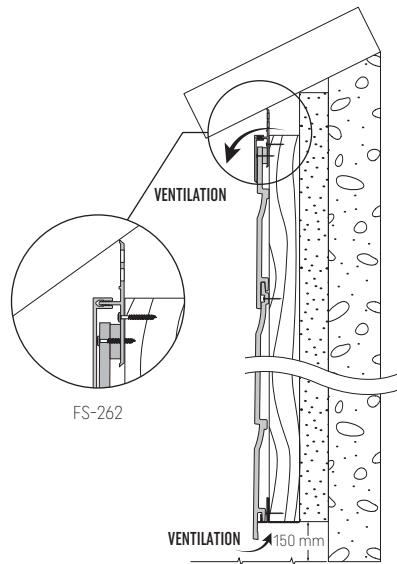

1B Ventilation under metalwork

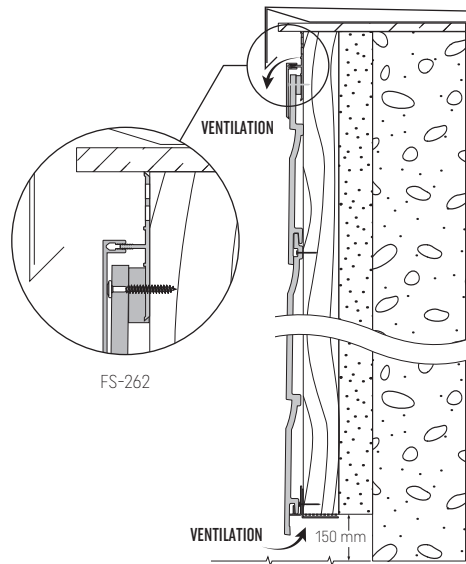

1C Ventilation under soffit boards

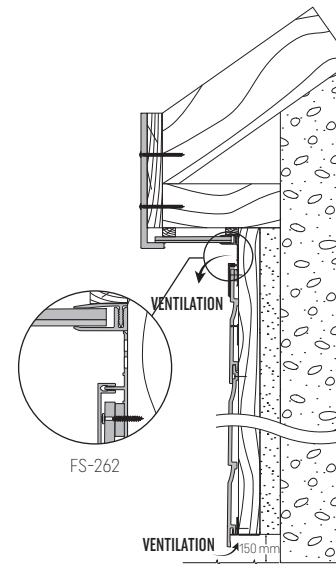

Windowsill

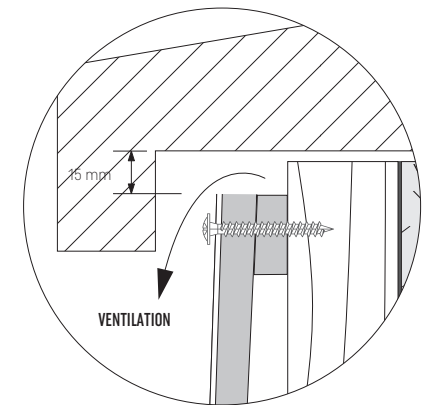

DILATATION

Proper allowance for expansion is made by:

- keeping sufficient expansion gaps at each board end
- screwing fasteners not too tight so that the boards can move freely
- positioning fasteners inside nail slots, at least 1 cm away from their extremes

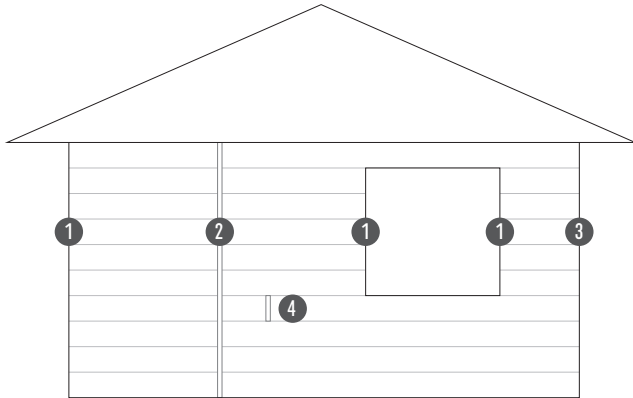

2 Center joint trim FS-282

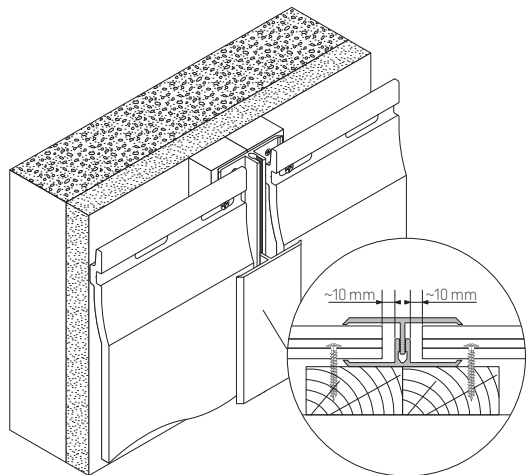

1 Universal corner FS-222

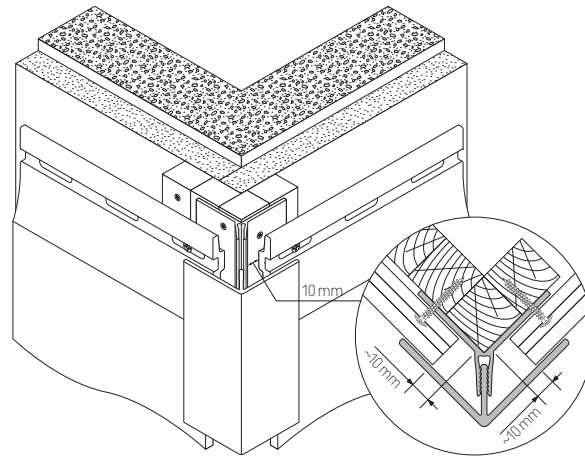

3 Finishing trim FS-252

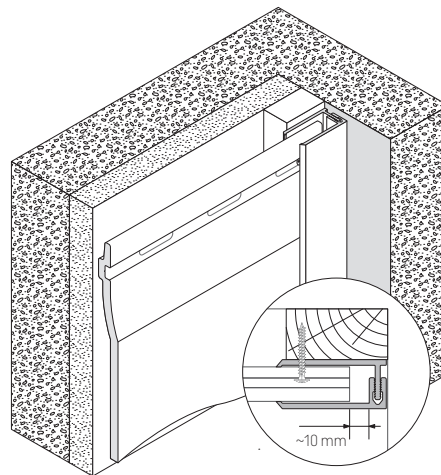

1 Universal corner FS-222

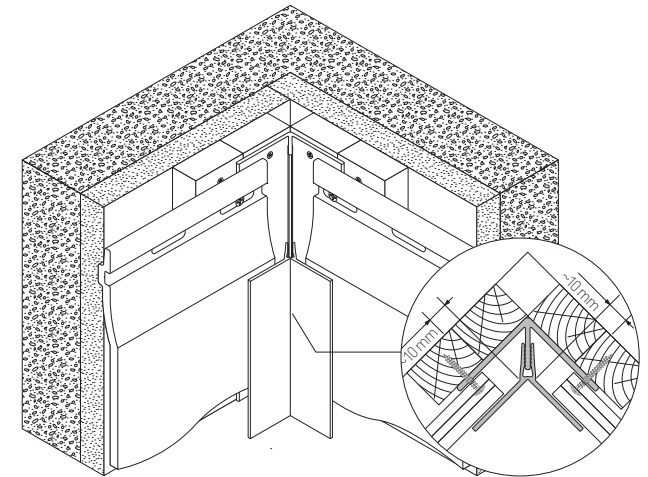

4 Joint cover J-201/ J-202/ J-302/ J-304

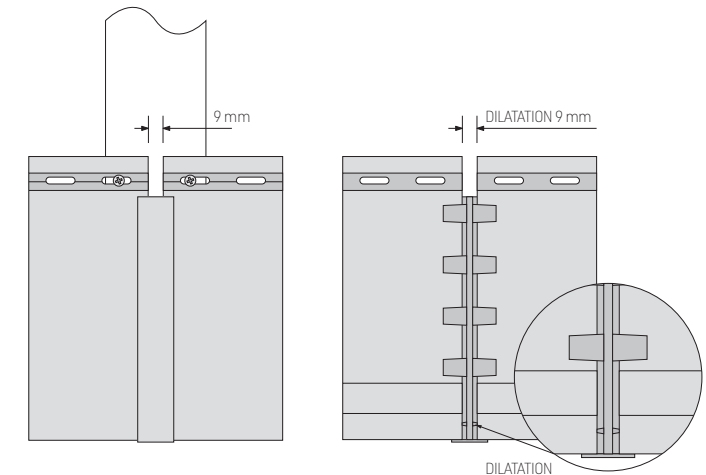

FRONT

BACK

FS-201/ FS-202/ FS-302/ FS-304 HORIZONTAL INSTALLATION - GENERAL RULES - VENTILATION GAP = 20 MM, see page 6

Pic. 1. KERRAFRONT 6 m - single board FS-201/ double board FS-202, FS-302/ fourfold board FS-304

Batten thickness dependent on the kind wall where the cladding is installed:
- timber frame wall: thickness 22 mm
- masonry (external insulation): thickness minimum 30 mm.

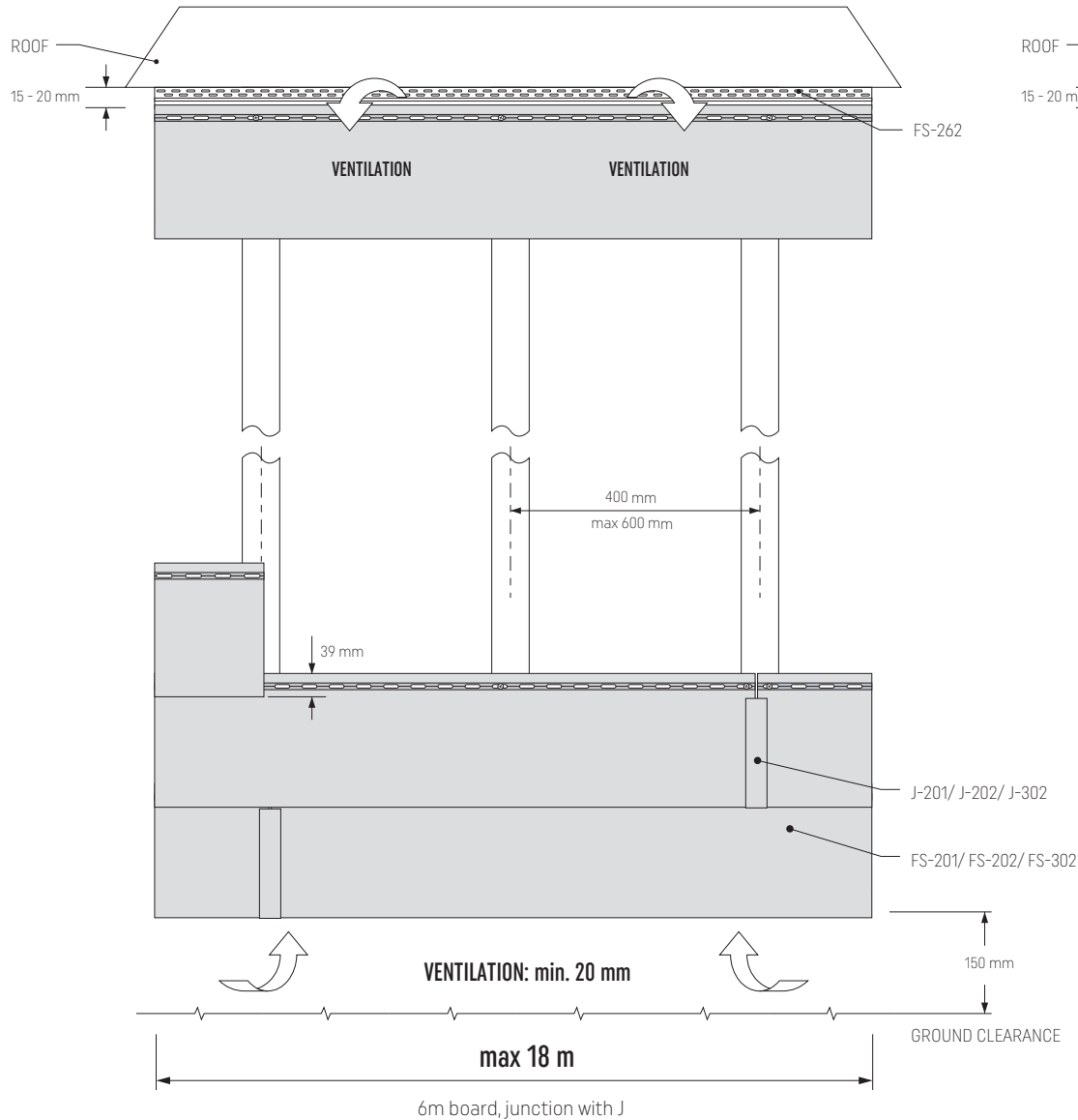

Pic. 2 KERRAFRONT CONNEX 2,95 m - single board FS-201/ double board FS-202, FS-302/ fourfold board FS-304

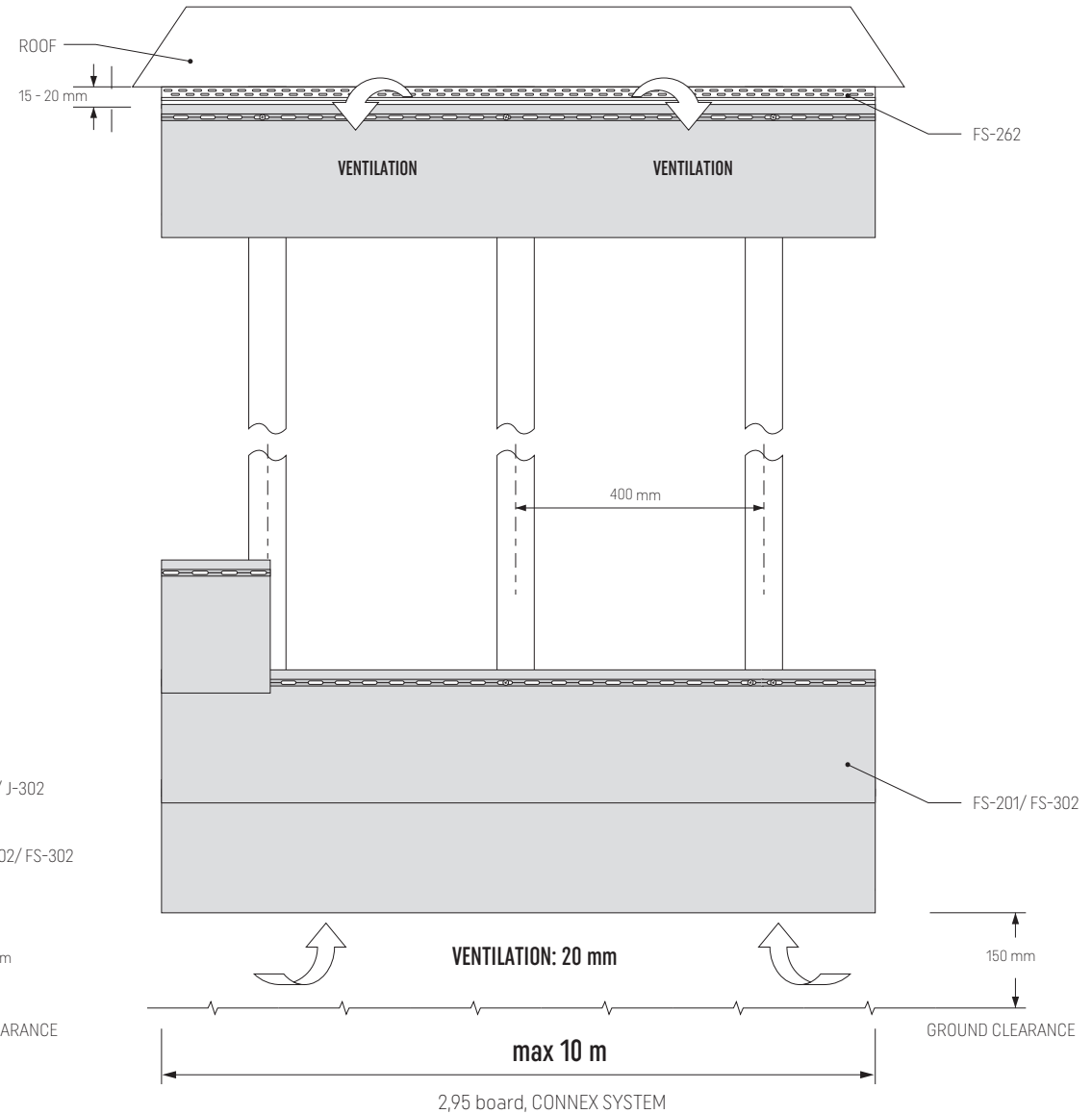

FS-201/ FS-301/ FS-202/ FS-302/ FS-304 - HORIZONTAL INSTALLATION - GENERAL RULES - VENTILATION GAP = 40 MM, see page 6

Pic. 3. KERRAFRONT 6 m - single board FS-201, 301/ double board FS-202, FS-302/ fourfold board FS-304

Pic. 4. KERRAFRONT CONNEX 2,95 m - single board FS-201/ 301/ double board FS-202, FS-302/ fourfold board FS-304

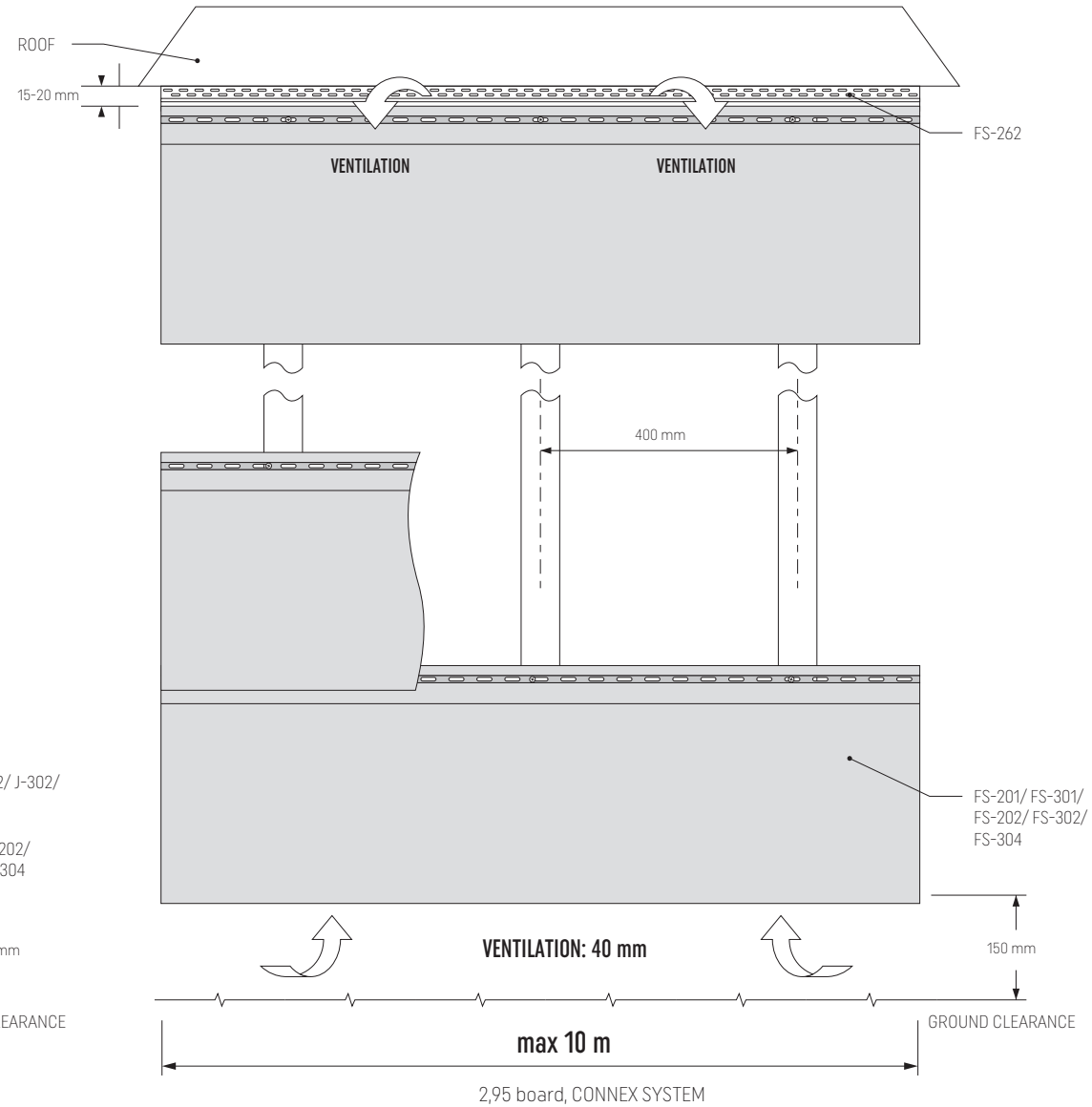
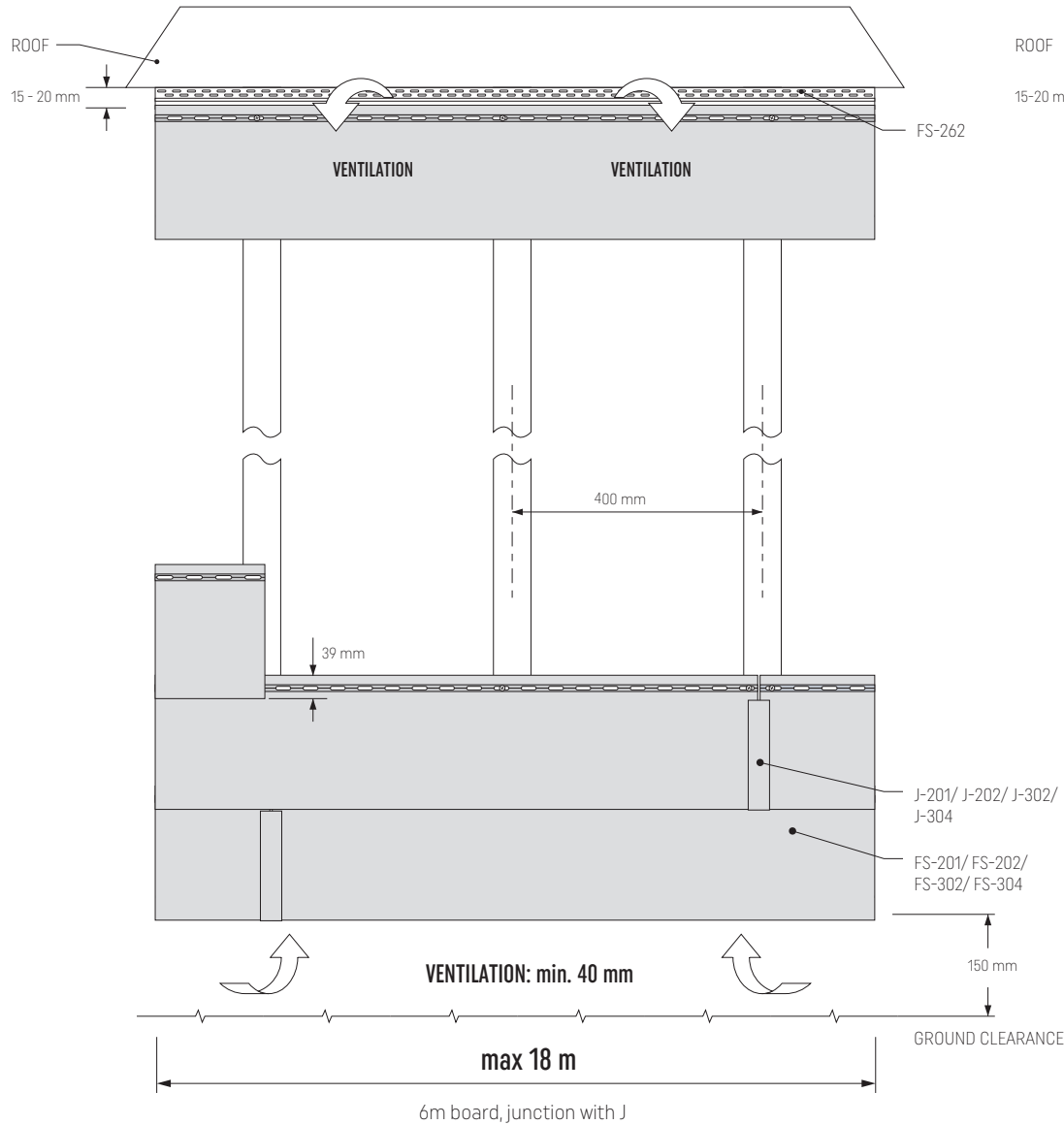

TRIMS AND ACCESSORIES

FS-211 Starter trim

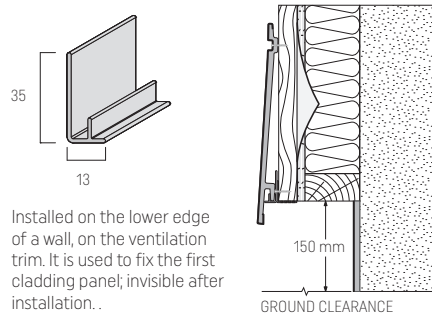

Installed on the lower edge of a wall, on the ventilation trim. It is used to fix the first cladding panel; invisible after installation.

FS-252 Finishing trim, 2-piece

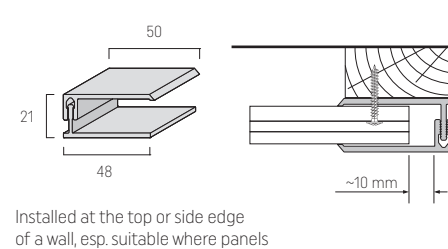

Installed at the top or side edge of a wall, esp. suitable where panels have been cut to required height.

FS-222 Universal corner, 2-piece

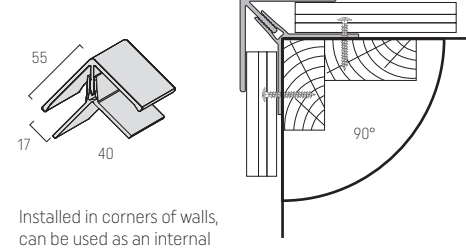

Installed in corners of walls, can be used as an internal or external corner detail.

FS-262 Ventilation trim, 2-piece

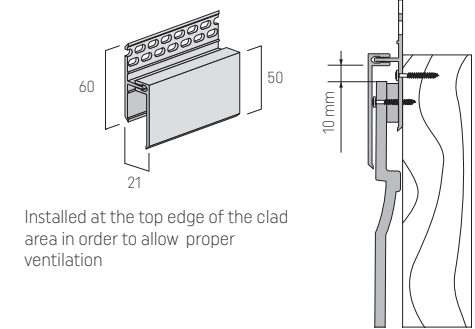

Installed at the top edge of the clad area in order to allow proper ventilation

FS-251 Universal trim

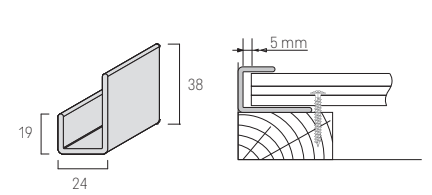

Installed vertically on a side edge or along a diagonal top edge of a wall, can be used as an alternative to FS-252 trim.

FS-261 FS-261 Perforated trim

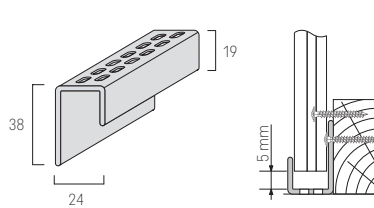

FS-282 Center joint trim 2 pieces

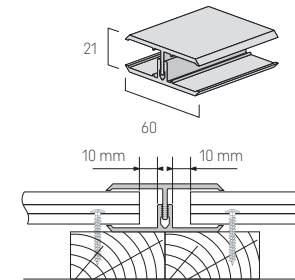

Installed vertically for continuous joints between cladding boards on a wall.

SV-11,5 Bottom ventilation trim

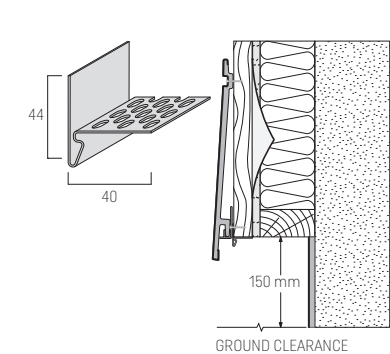

J-201 Joint cover for FS-201

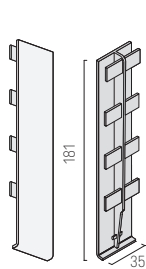

Installed between adjacent panels, always on a supporting batten, in order to butt-joint FS-201 cladding boards.

J-202 Joint cover for FS-202

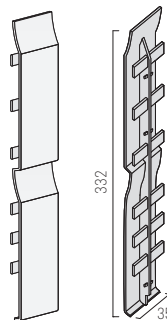

Installed between adjacent panels, always on a supporting batten, in order to butt-joint FS-202 cladding boards.

J-302 Joint cover for FS-302

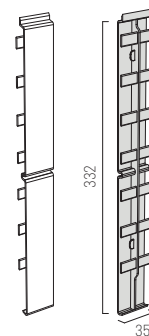

Installed between adjacent panels, always on a supporting batten, in order to butt-joint FS-302 cladding boards.

J-304 Joint cover for FS-304

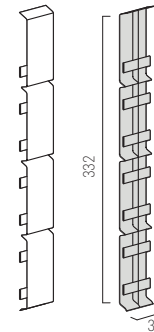

Installed between adjacent panels, always on a supporting batten, in order to butt-joint FS-304 cladding boards.

INOX-UP3.5X35-TX15-A2 Fitting screw

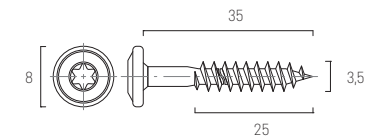

Usage per 1 m²:
single board FS-201: 15 pcs
single board FS-301: 9 pcs
double board FS-202: 9 pcs
double board FS-302: 9 pcs
fourfold board FS-304: 9 pcs

PRINCIPLES OF POSITIONING THE SCREWS IN THE FIXING HOLES

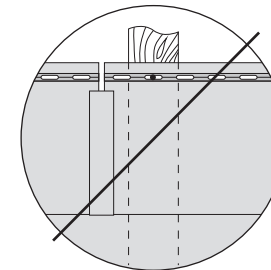
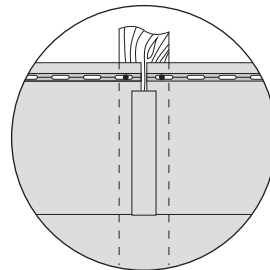
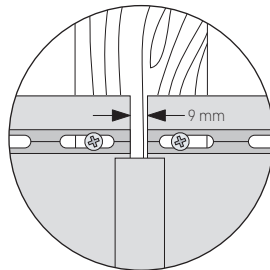
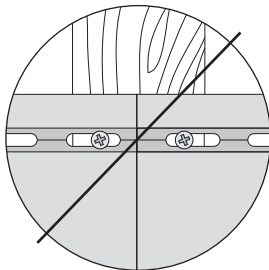
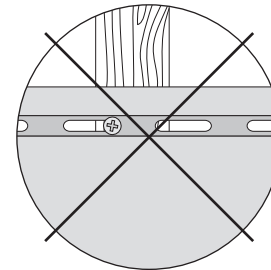
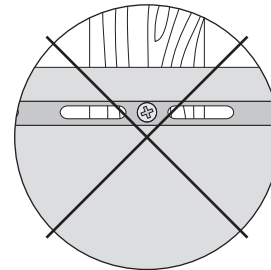
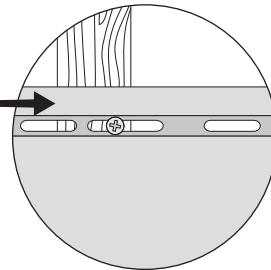
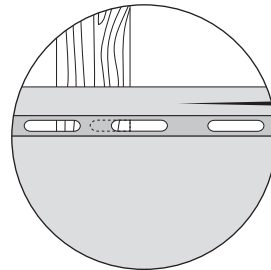
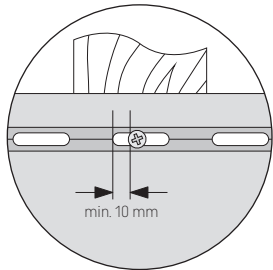
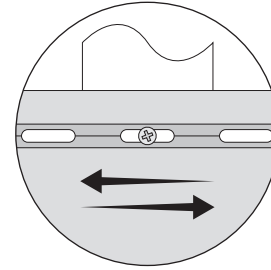
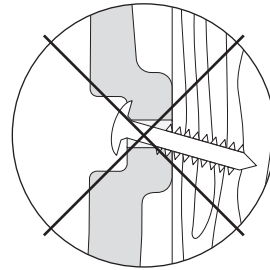
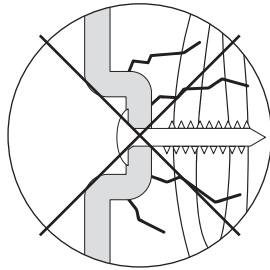
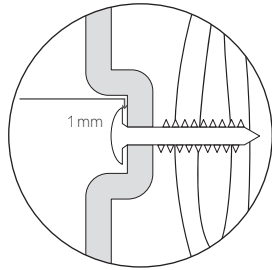

min. 10 mm

9 mm

HORIZONTAL INSTALLATION - GENERAL RULES

Pic. 5. Rules for joining the cladding profiles (FS-201 / FS-202 / FS-302 / FS-304) with (J-201/ J-202/ J-302 / J-304) joint covers

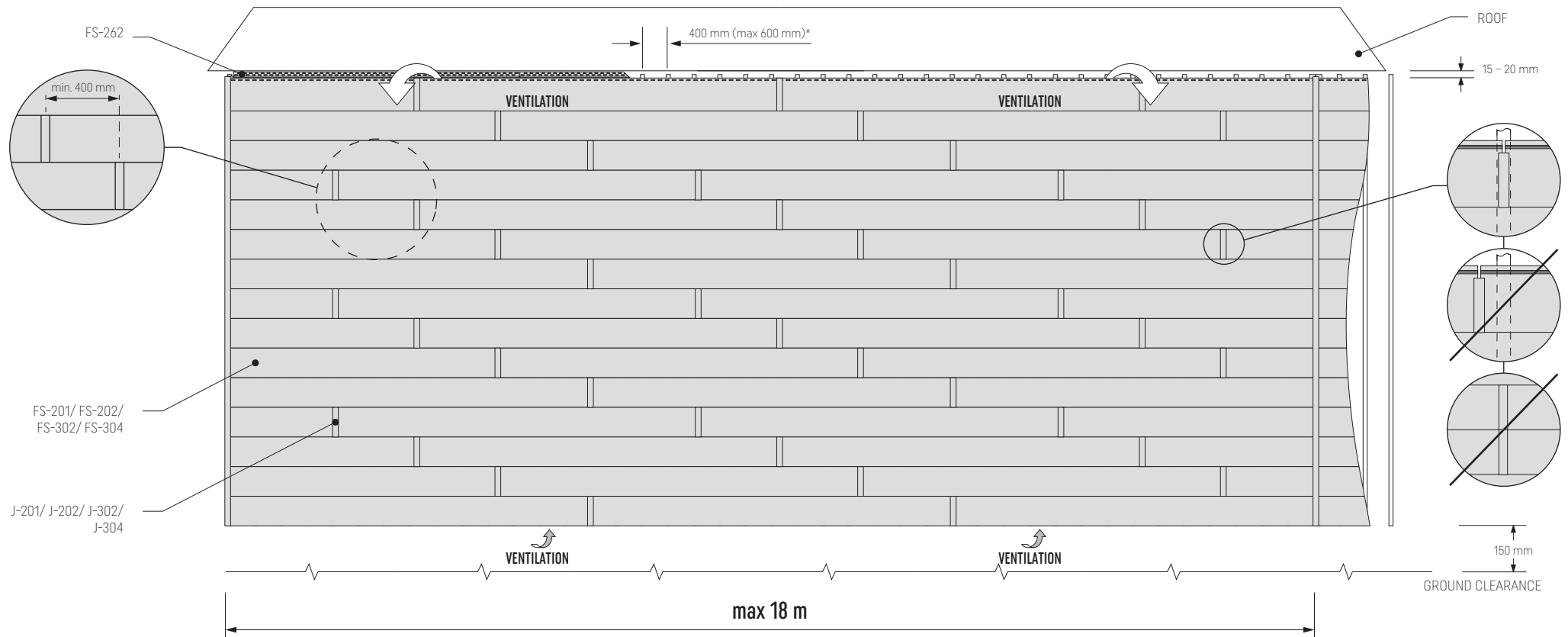

* see page 6

HORIZONTAL INSTALLATION - GENERAL RULES

Pic. 6. Joining the cladding profiles (FS-201/ FS-202/ FS-301/ FS-302/ FS-304) with FS-282 trim

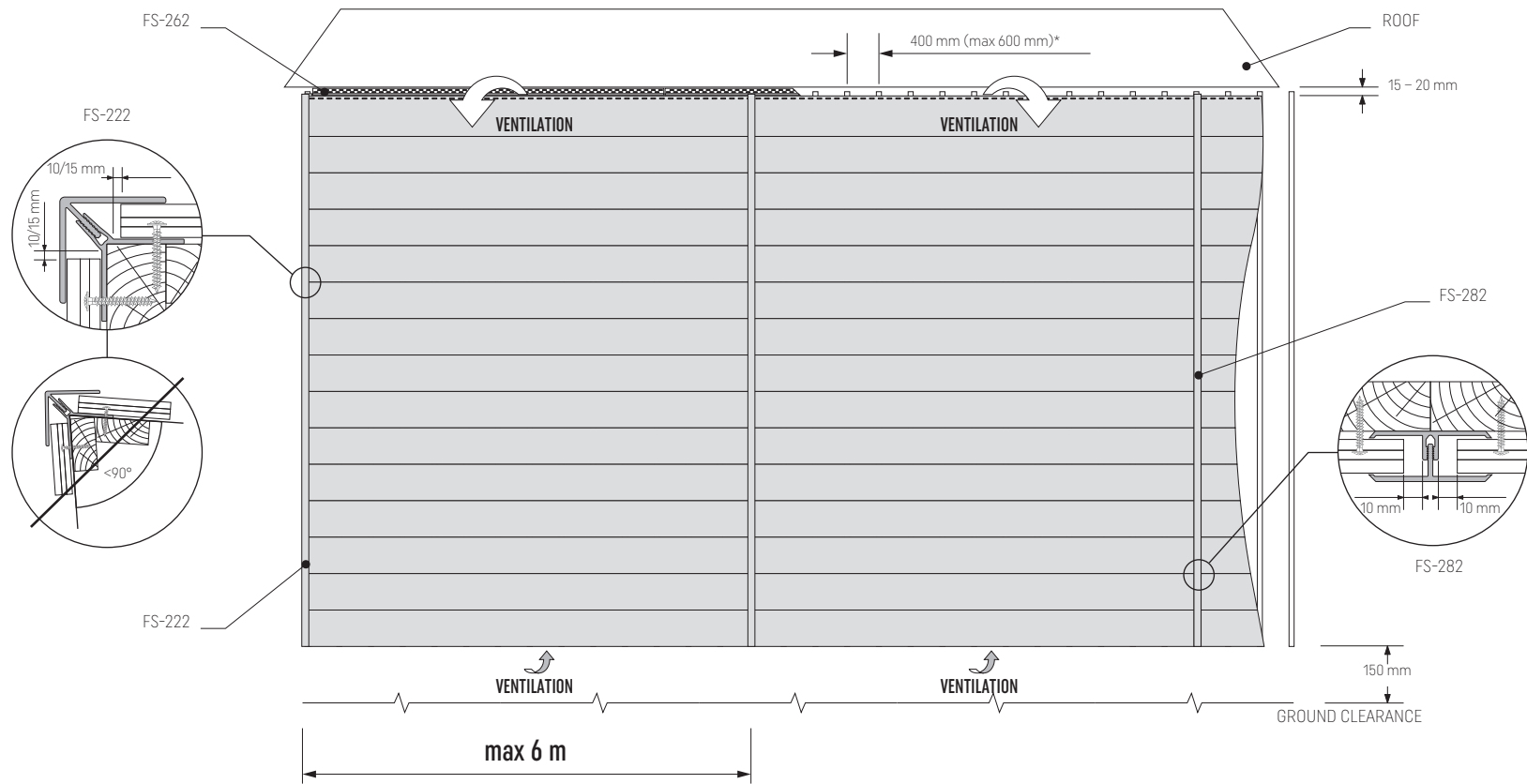

* see page 6

HORIZONTAL INSTALLATION - SYSTEM CONNEX

Pic. 7. Rules for joining the cladding profiles (FS-201/ FS-301 / FS-302 / FS-304) - system CONNEX

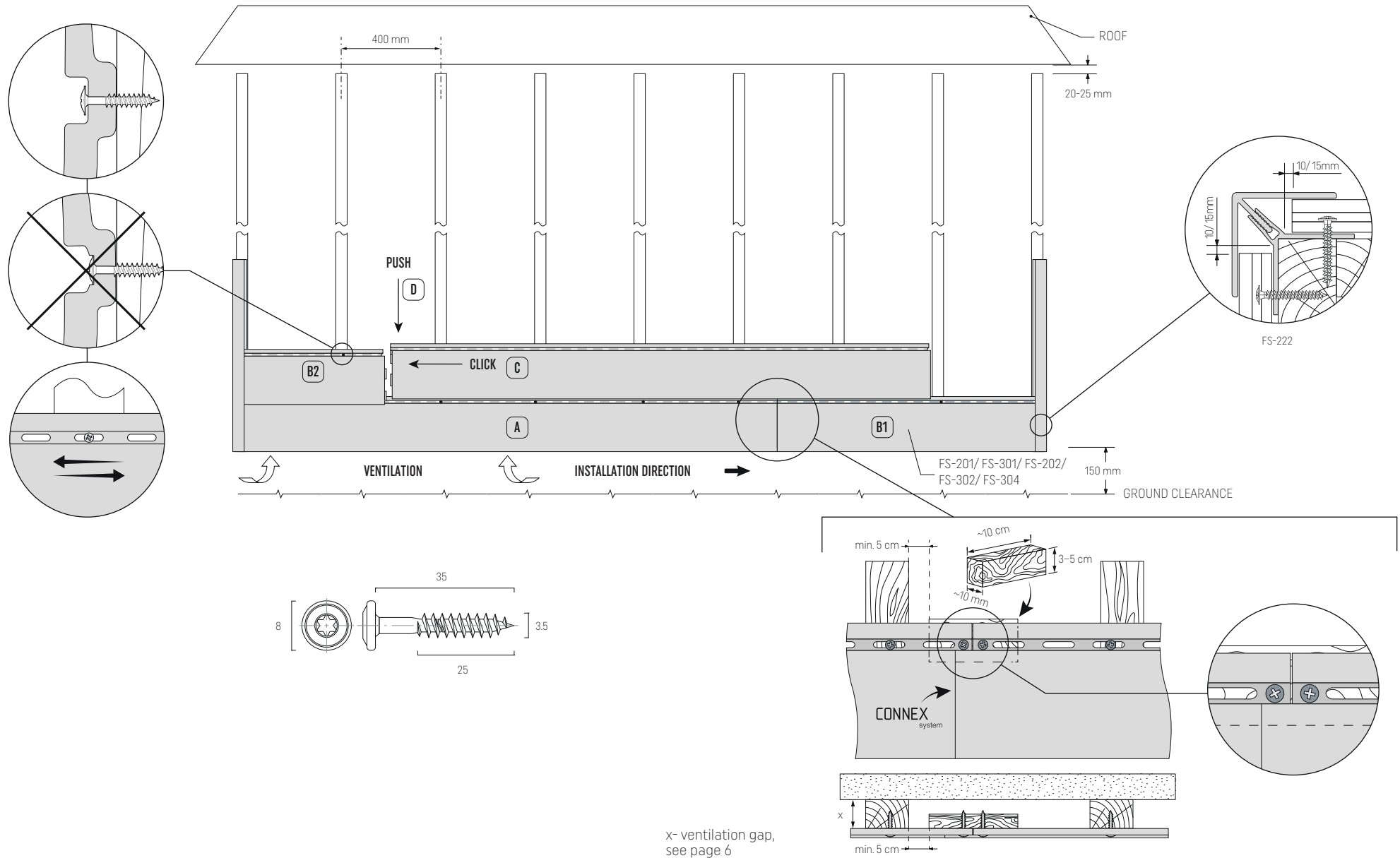

x- ventilation gap, see page 6

HORIZONTAL INSTALLATION - SYSTEM CONNEX

Pic. 8. Rules for joining the cladding profiles (FS-201/ FS-301/ FS-202/ FS-302/ FS-304) - system CONNEX 2,95 ml

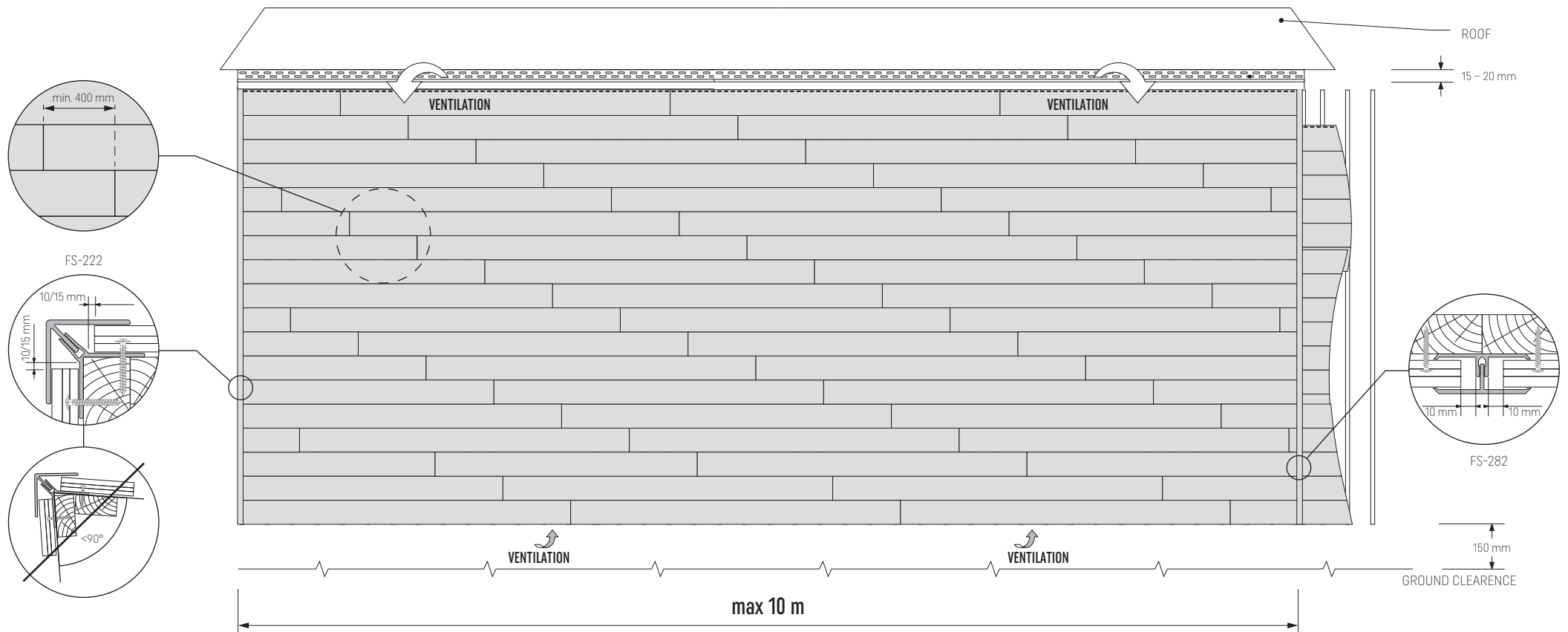

HORIZONTAL INSTALLATION ON A TIMBER FRAME WALL

Pic. 9. KERRAFRONT Siding boards on a timber frame wall - vertical section

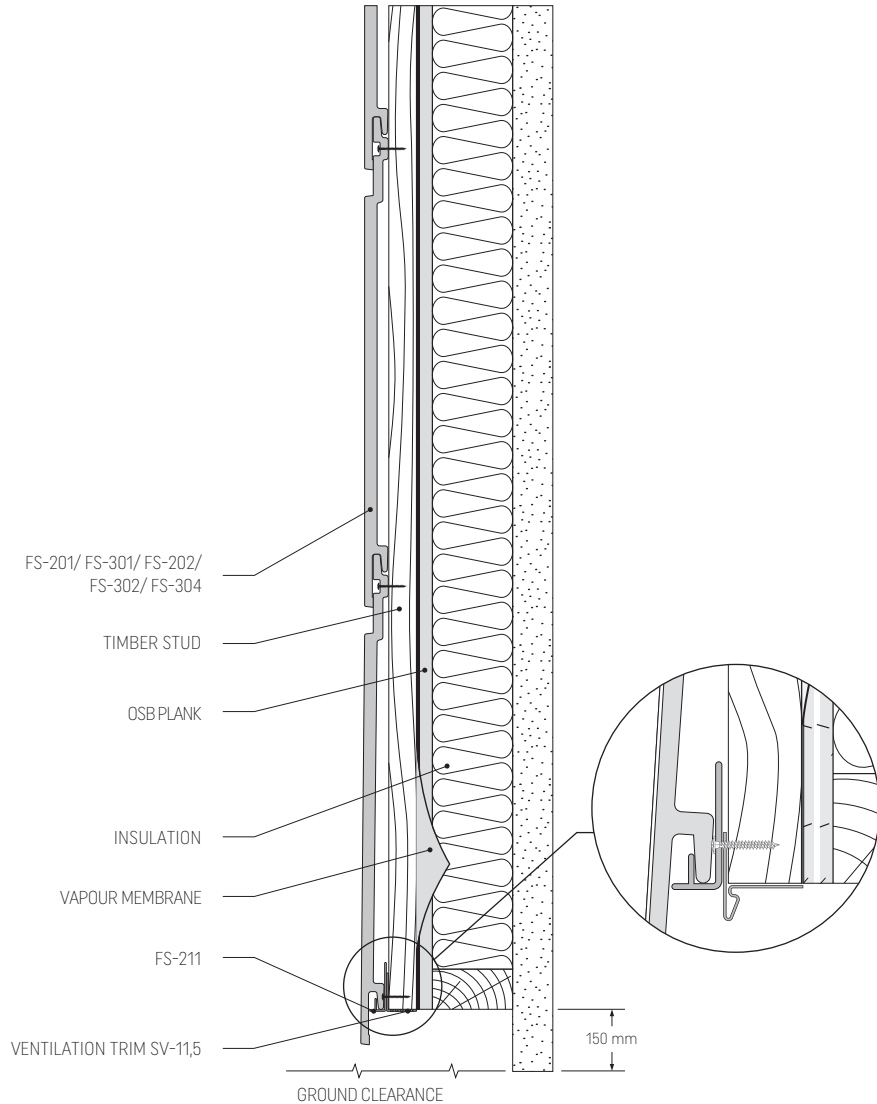

Pic. 10. Ventilation gap 20 mm required - horizontal section, see page 6

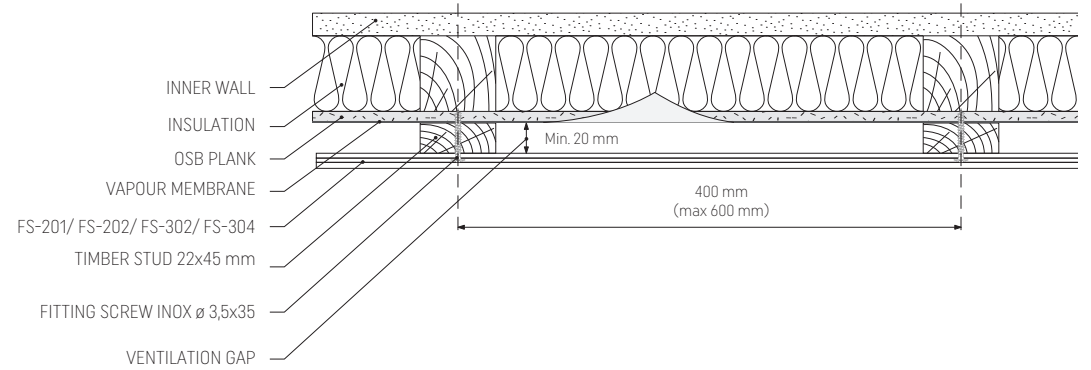

Pic. 11. Ventilation gap 40 mm required - horizontal section, see page 6

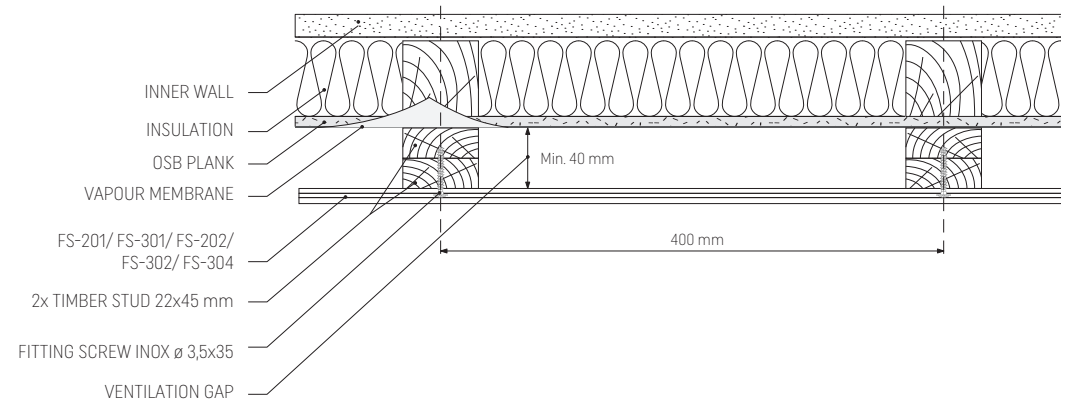

INSTALLATION AROUND WINDOWS, TIMBER FRAME WALL

Pic. 12. KERRAFRONT Joinery detail on a timber frame wall - vertical section

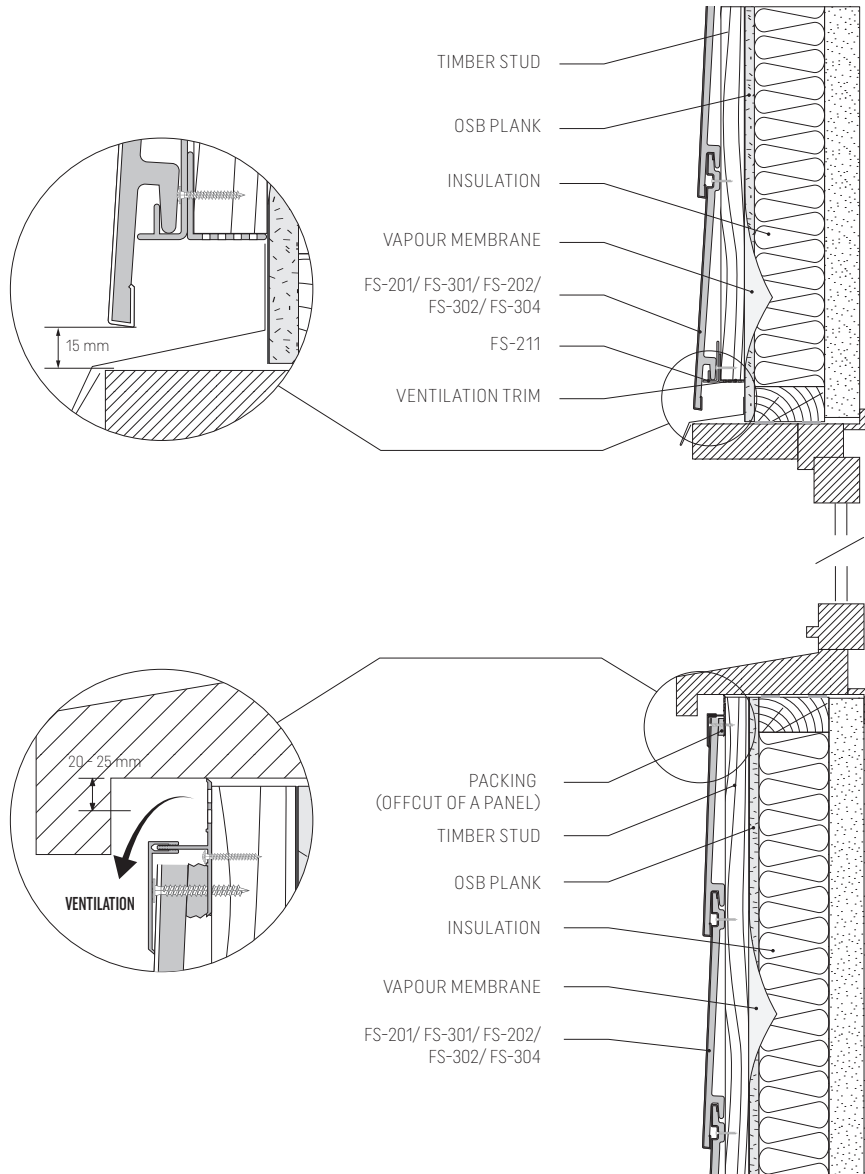

Pic. 13. KERRAFRONT Joinery corner detail on a timber frame wall - horizontal section

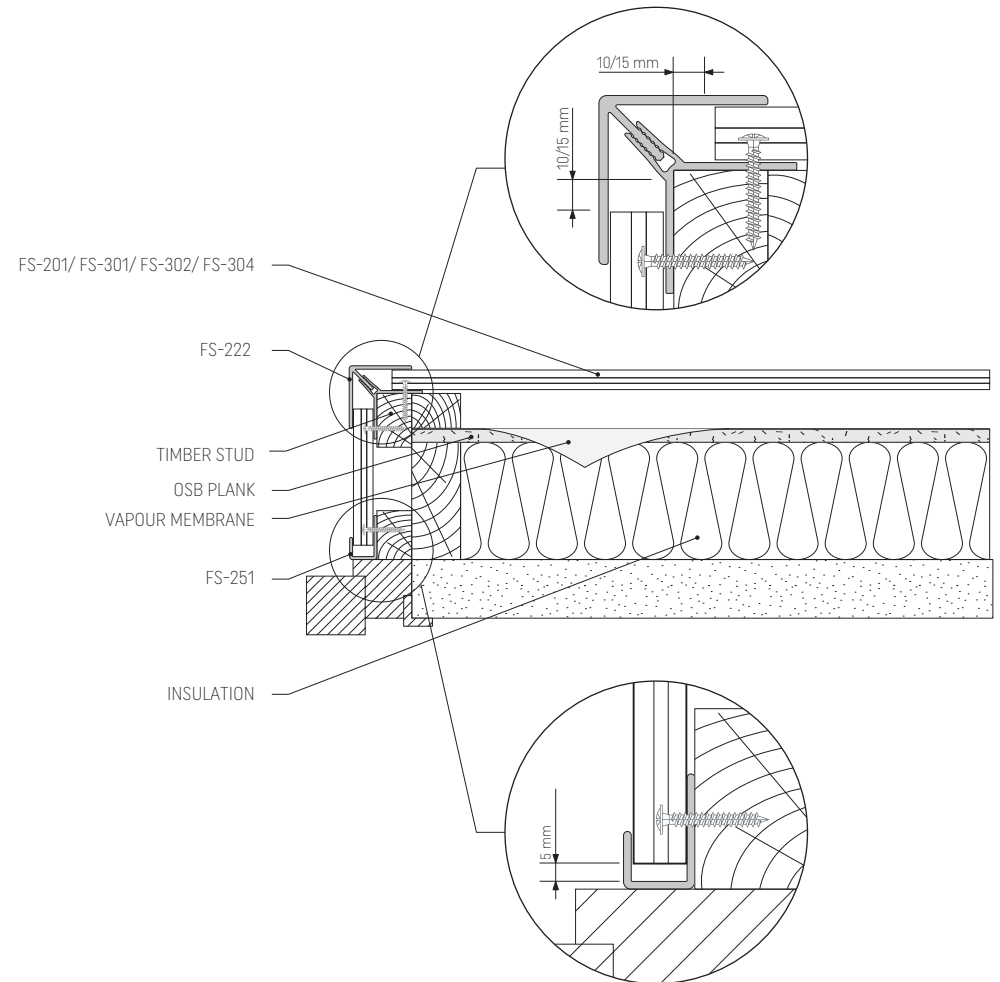

HORIZONTAL INSTALLATION ON MASONRY

Pic. 14. Siding board, horizontal installation on masonry - vertical section

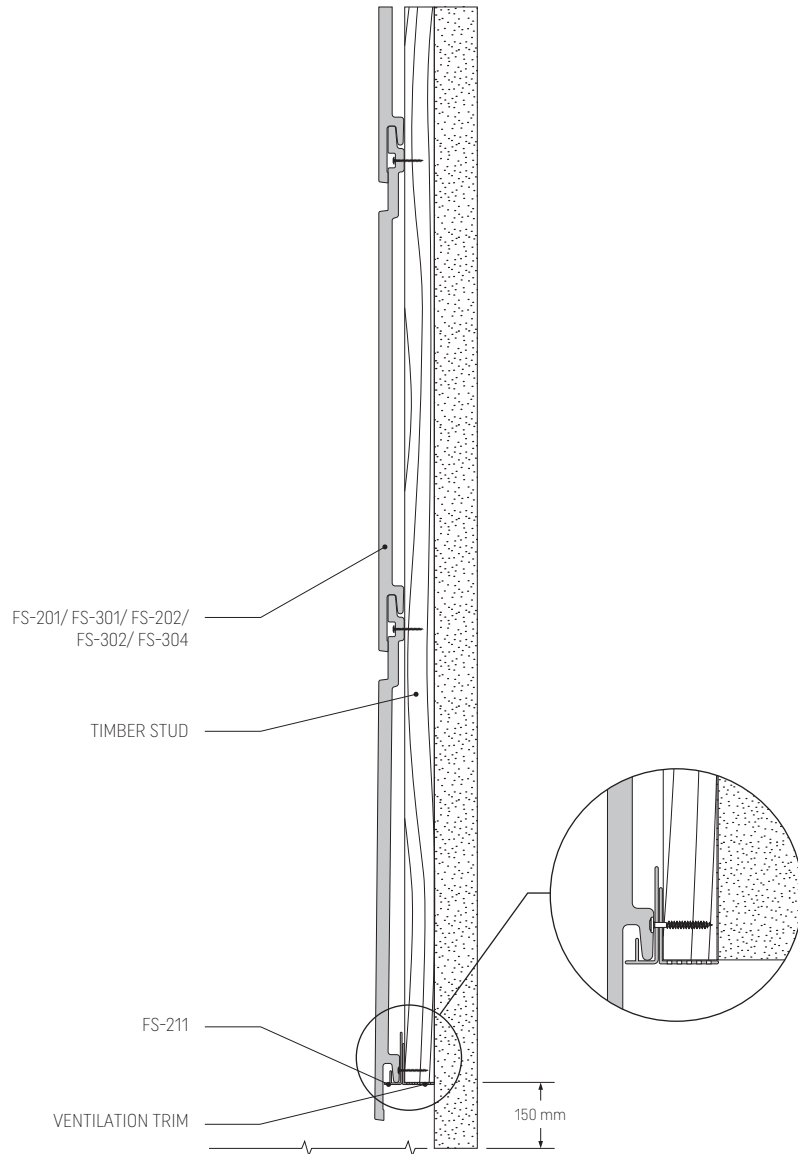

Pic. 15. Ventilation gap on masonry wall - horizontal section

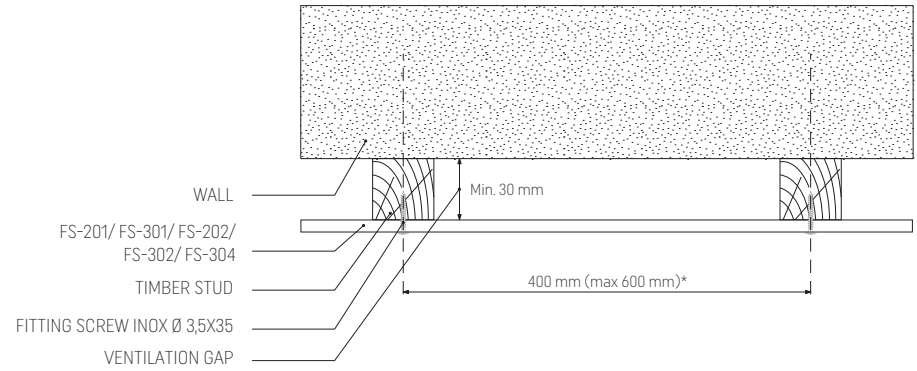

* see page 6

Pic. 16. Ventilation gap required on insulated masonry wall between studs - horizontal section

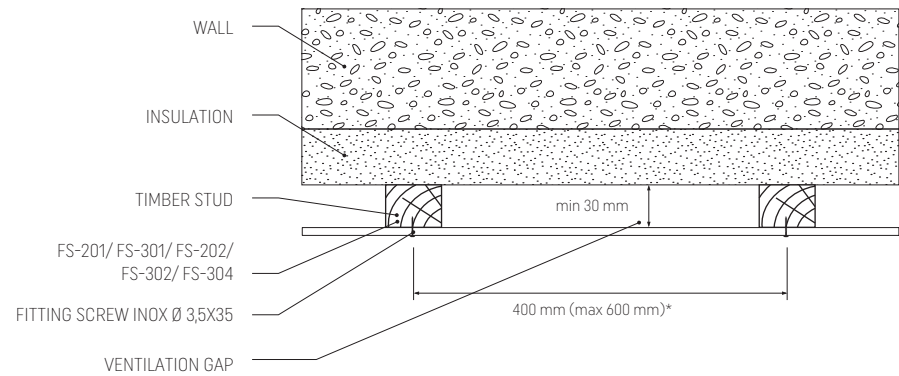

* see page 6

INSTALLATION ON MASONRY WALL WITH METAL BRACKETS

Pic. 17. Siding board on insulated masonry wall with brackets - vertical section

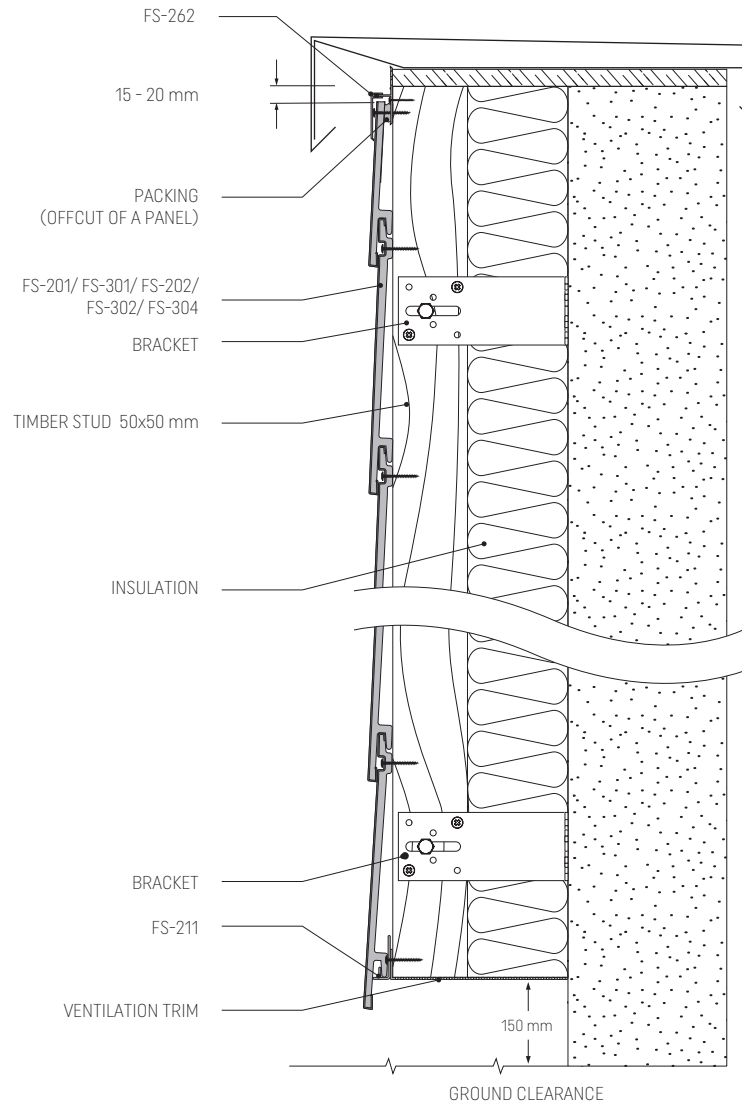

Pic. 18. Ventilation gap required on insulated masonry wall with brackets - vertical section

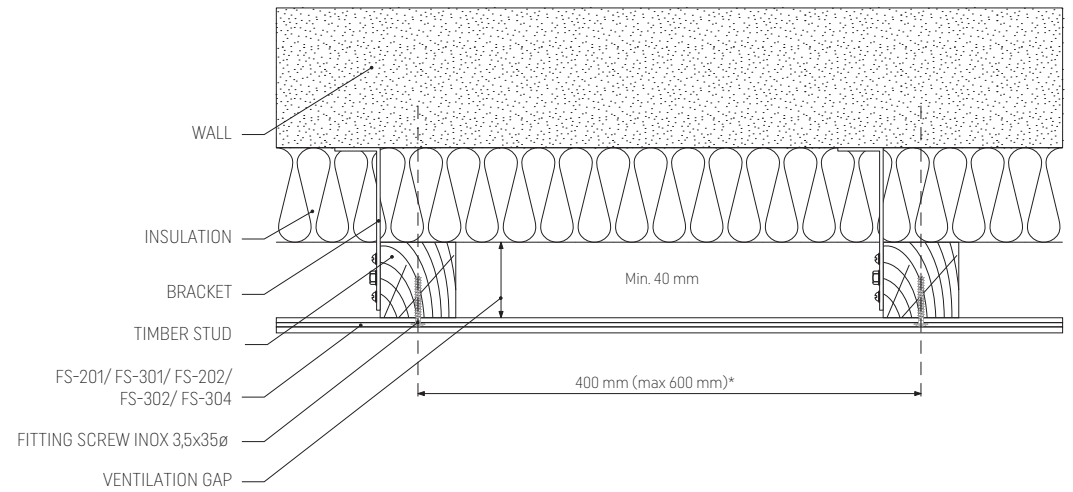

* see page 6

INSTALLATION AROUND WINDOWS WITH METAL BRACKETS

Pic. 19. Joinery detail on insulated masonry wall - vertical section

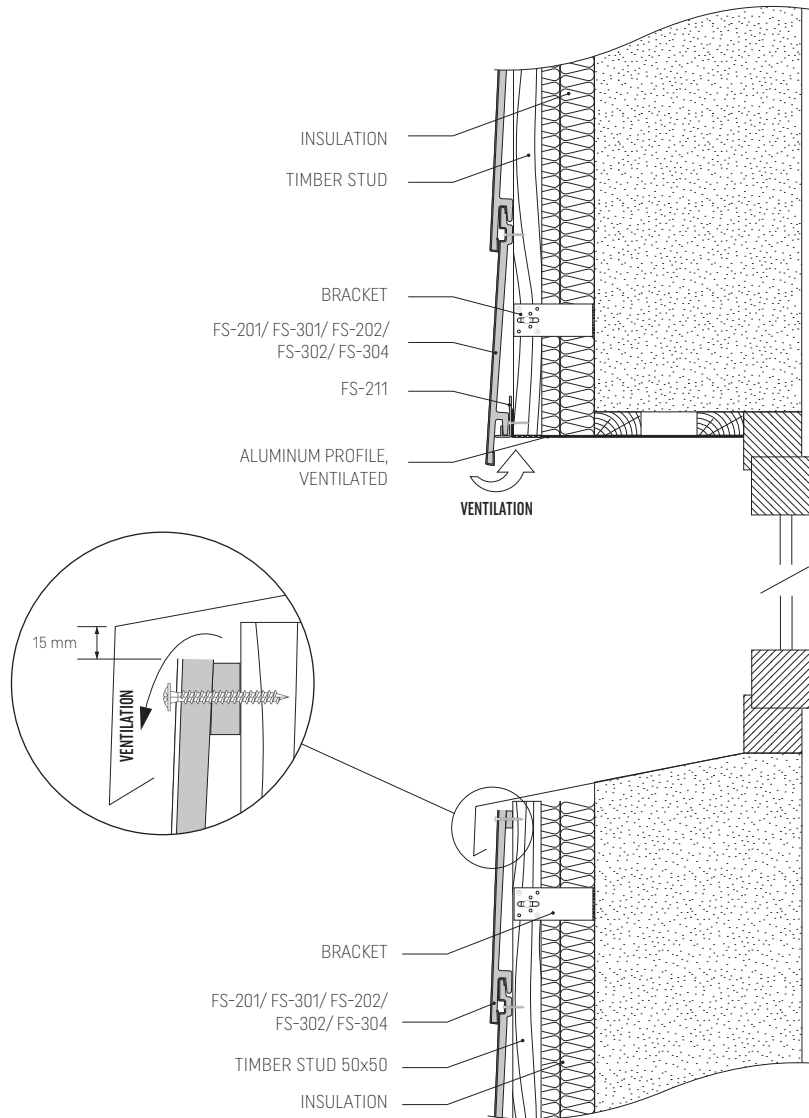

Pic. 20. Joinery corner detail on insulated masonry wall - horizontal section

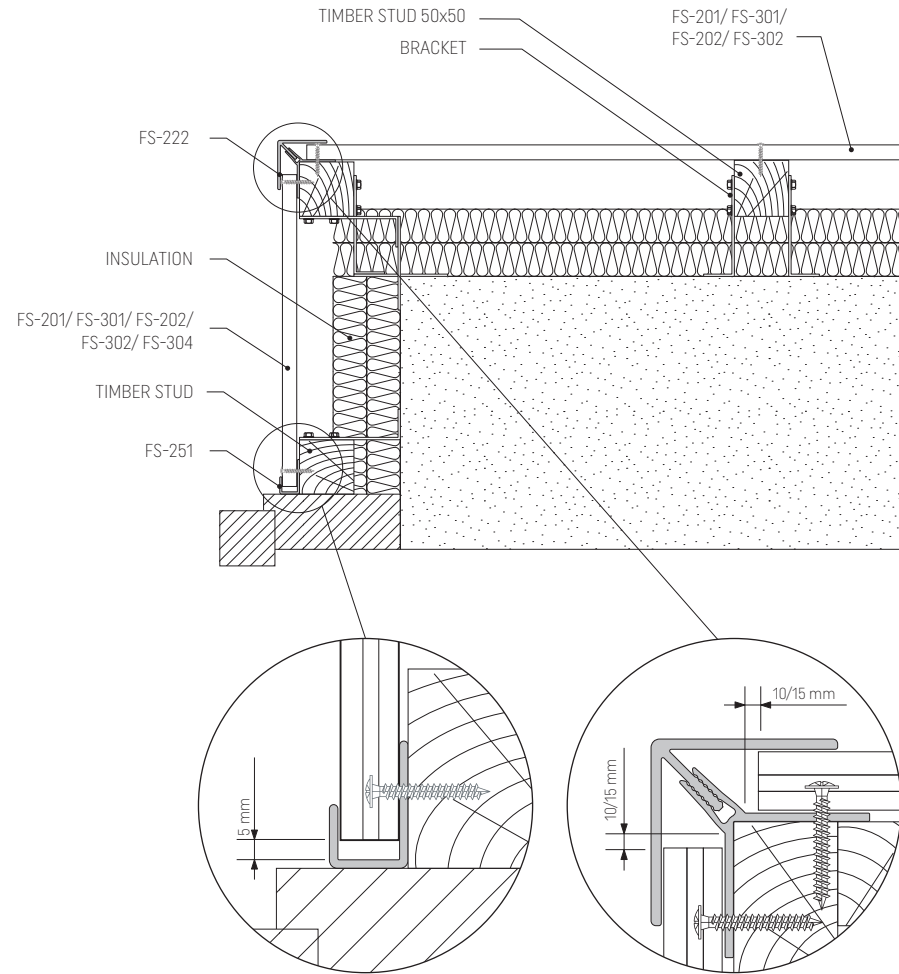

VERTICAL INSTALLATION FS-301/ FS-202/ FS-302/ FS-304

Pic. 21. KERRAFRONT Single board FS-301/ double board FS-202/ FS-302 / fourfold board FS-304

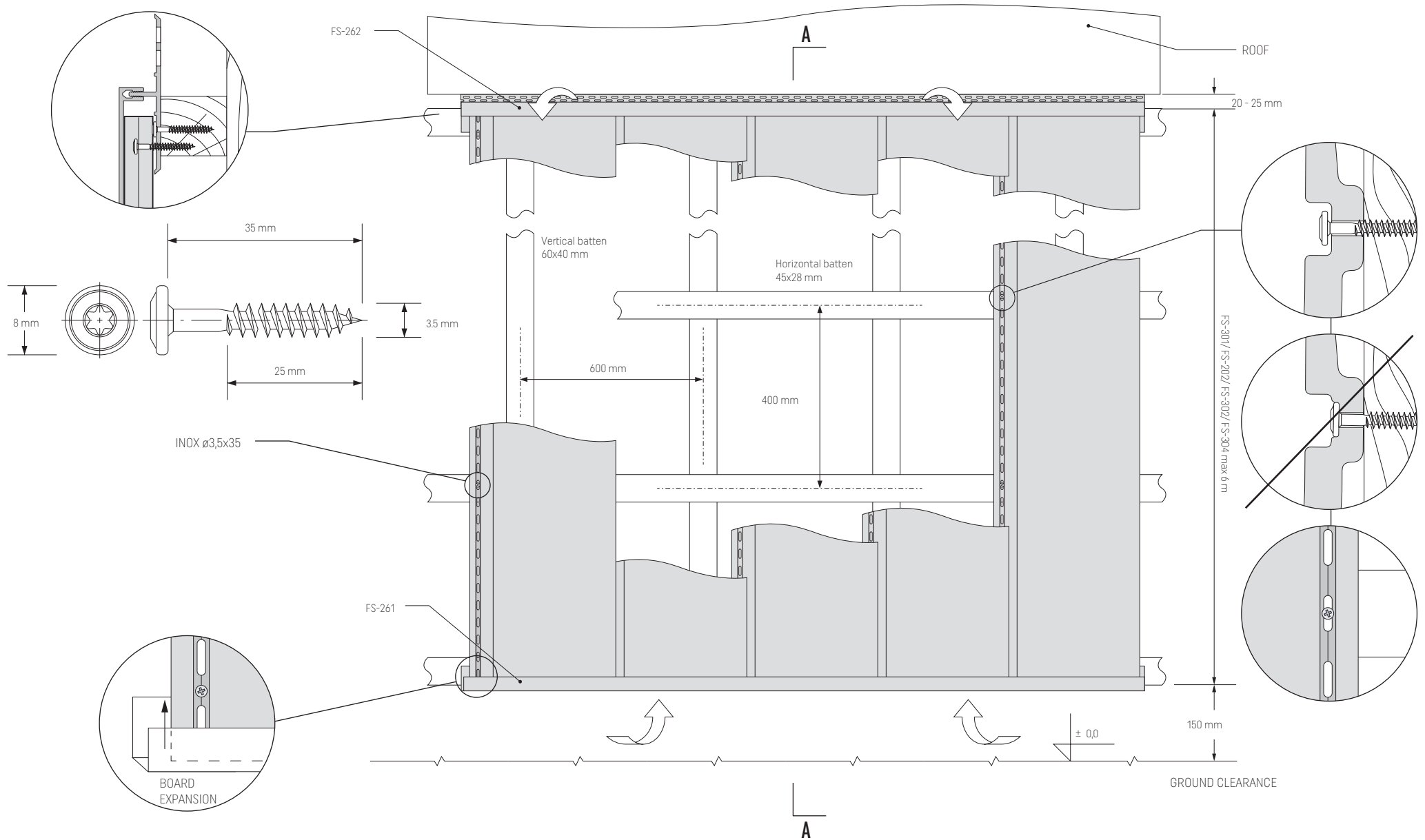

VERTICAL INSTALLATION FS-301/ FS-202/ FS-302/ FS-304, DRIP EDGE TRIM

Pic. 22. Single board FS-301/ double board FS-202/ 302/ fourfold board FS-304, A-A section

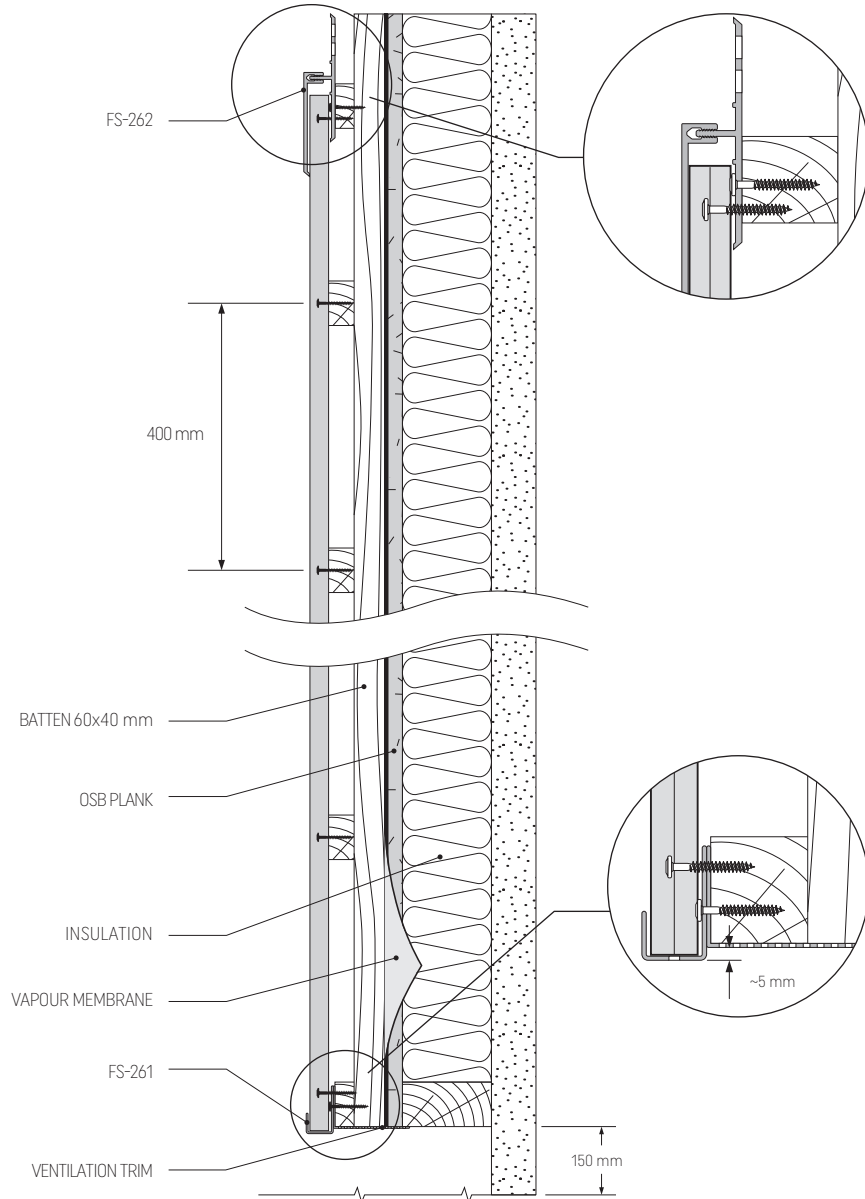

Pic. 23. Drip edge trim, detail

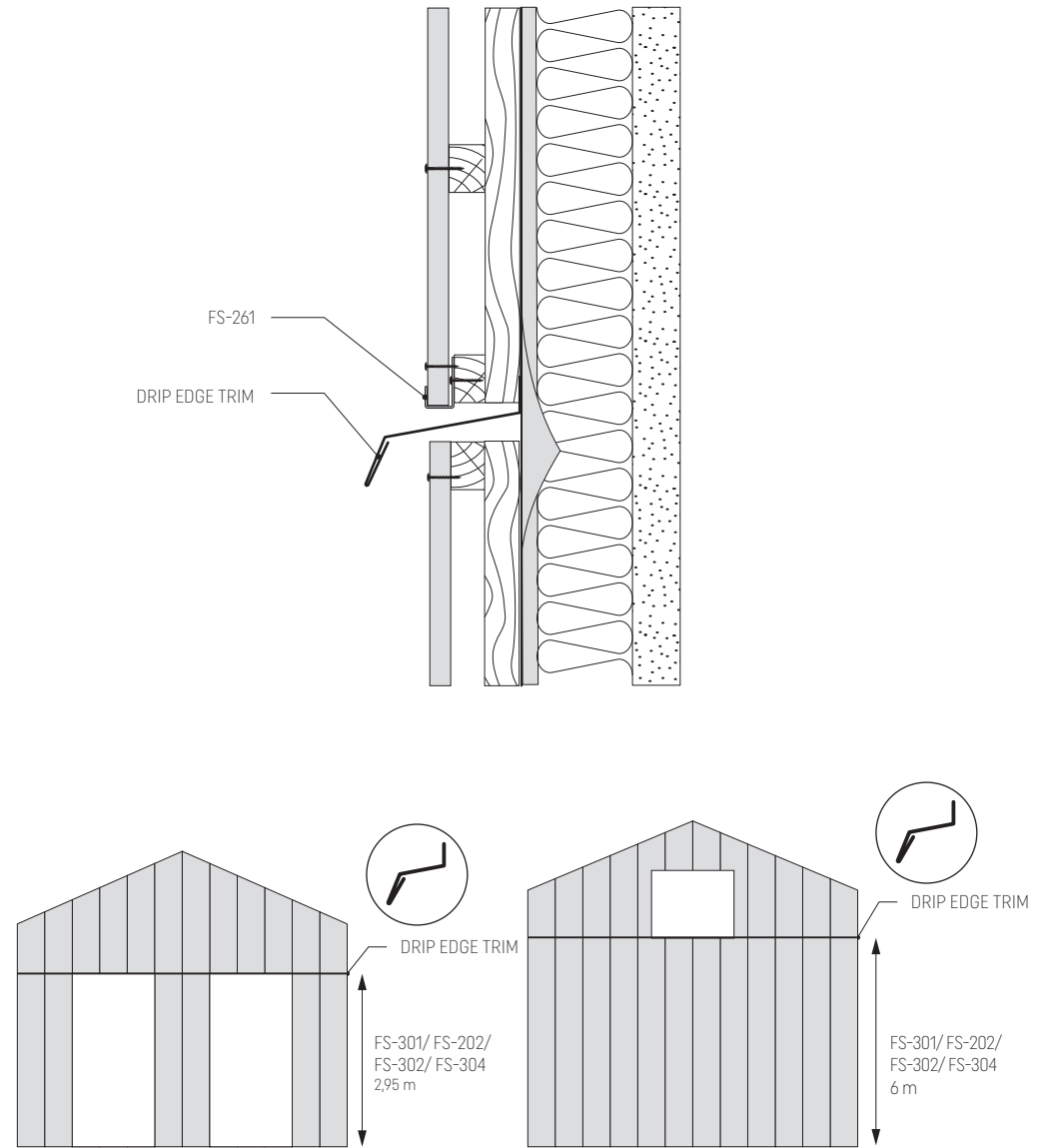

VERTICAL INSTALLATION FS-301/ FS-202/ FS-302/ FS-304

Pic. 24. Joinery detail on insulated masonry wall - vertical section

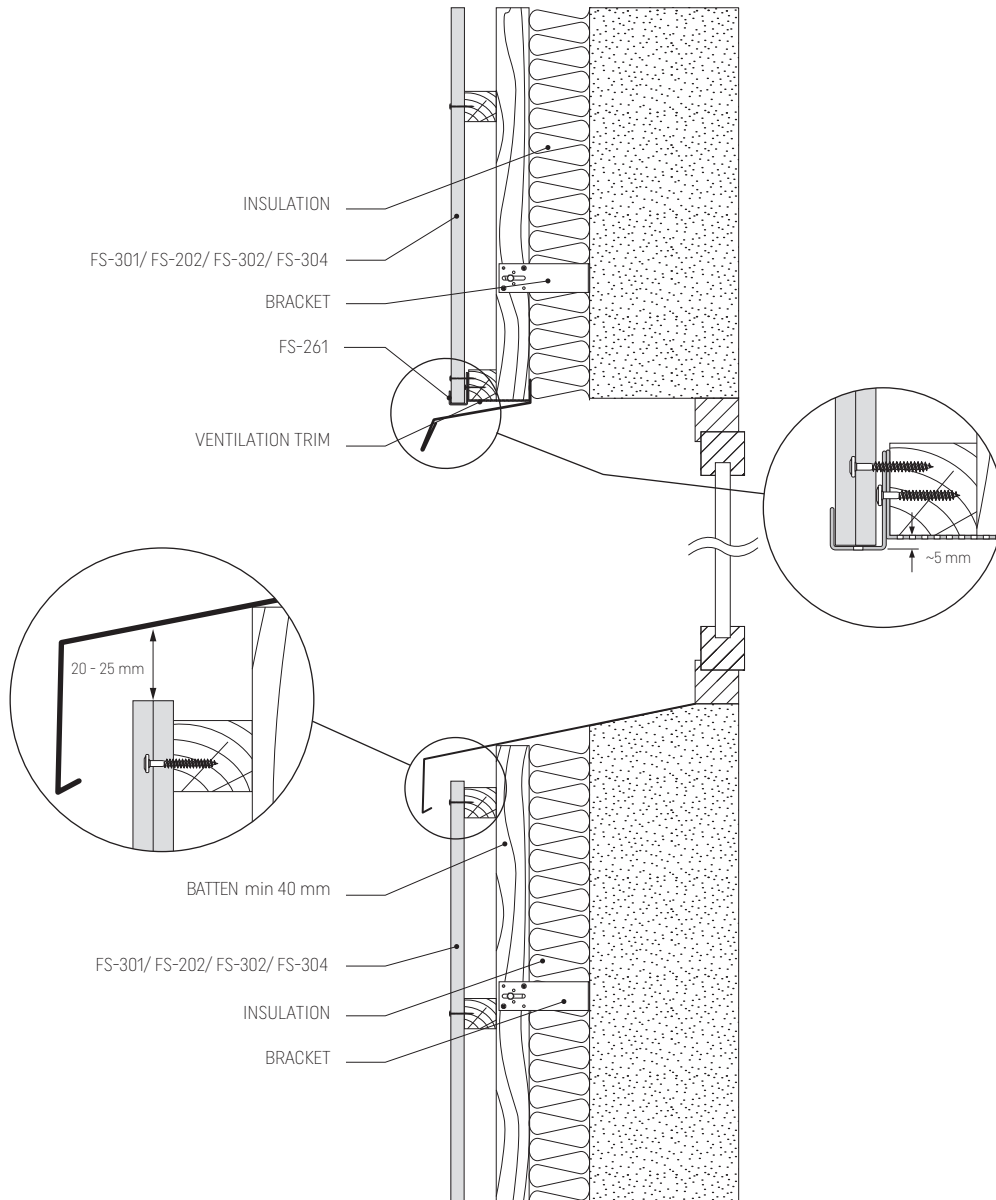

Pic. Joinery corner detail on insulated masonry wall - horizontal section

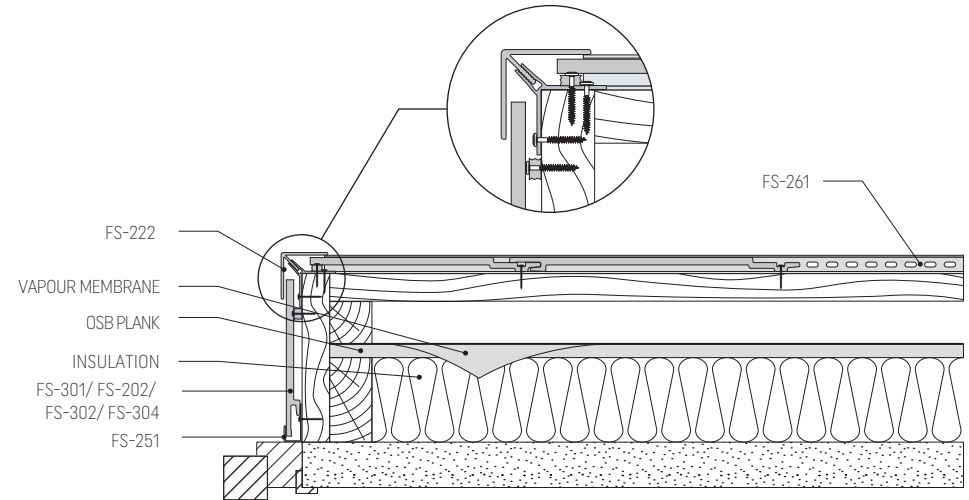

KERRAFRONT

TECHNICAL DATA SHEET

TYPE OF THE BOARD/ COLLECTION	TYPE	FINISH	MATERIAL - CORE	TOTAL WIDTH	COVERING WIDTH	LENGTH	TOTAL WIDTH	THICKNESS (THINNEST POINT)	THICKNESS (THICKEST POINT)
Fourfold board MODERN WOOD, WOOD EFFECT	FS-304 Fourfold board	Embossed woodgrain	Foamed closed -cell PVC (PVC-UE)	372 mm	332 mm	MODERN WOOD FS-304, length 6000 mm MODERN WOOD FS-304 CONNEX, length 2950 mm	Average weight per m ² : 4,95 kg	4,0 mm by bottom lock	18 mm
		Foiled				Foiled foamed closed-cell PVC (PVC-UE)			
Double board MODERN WOOD, WOOD EFFECT	FS-302 Double board	Embossed woodgrain	Foamed closed -cell PVC (PVC-UE)	372 mm	332 mm	MODERN WOOD FS-302, length 6000 mm MODERN WOOD FS-302 CONNEX, length 2950 mm	Average weight perm ² : 4,84 kg	6,5 mm	18 mm
		MODERN WOOD (7 colours): White (WH), Ivory (IV), Claystone (CS), Beige (BE), Pearl Grey (PG), Quartz Grey (QG), Anthracite (AN)							
Double board CLASSIC RETRO RUSTIC	FS-202 Double board	Embossed woodgrain	Foamed closed -cell PVC (PVC-UE)	371 mm	332 mm	CLASSIC FS-202, length 6000 mm	Average weight per m ² : 4,31 kg	6,5 mm	18 mm
		CLASSIC (9 colours): White (WH), Cream (CR), Beige (BE), Claystone (CS), Light Grey (LG), Grey (GR), Quartz Grey (QG), Olive (OL), Anthracite (AN) RETRO (4 colours): Cream (CR), Beige (BE), Sand (SA), Blue (BL) RUSTIC (3 colours): Tawny (TA), Aqua Blue (AB), Sky Grey (SKG)				Foamed closed -cell PVC (PVC-UE COLORBLEND)			

KERRAFRONT

TECHNICAL DATA SHEET

TYPE OF THE BOARD/ COLLECTION	TYPE	FINISH	MATERIAL - CORE	TOTAL WIDTH	COVERING WIDTH	LENGTH	TOTAL WIDTH	THICKNESS (THINNEST POINT)	THICKNESS (THICKEST POINT)
Single board CLASSIC WOOD DESIGN RUSTIC WOOD EFFECT	FS-201 Single board	Embossed woodgrain	Foamed closed -cell PVC (PVC-UE)	219 mm	180 mm	CLASSIC FS-201, lenght 6000 mm CLASSIC FS-201 CONNEX, lenght 2950 mm WOOD DESIGN FS-201, lenght 6000 mm WOOD DESIGN FS-201 CONNEX, lenght 2950 mm RUSTIC FS-201, lenght 6000 mm RUSTIC FS-201 CONNEX, lenght 2950 mm	Average weight per m ² : 4,56 kg	6,5 mm	18 mm
		Foiled WOOD EFFECT FOILED (4 colours): Malt Oak (MO), Alpine Oak (AL), Concrete Oak (CO), Caramel Oak (CAO)							
Single board TREND	FS-301 Single board	Single-color version with delicate structure (SOFT) and version with printed stone drawing (STONE)	Foamed closed -cell PVC (PVC-UE)	359 mm	320 mm	TREND FS-301 CONNEX, lenght 2950 mm dimension tolerance: 2950 mm + 9 mm max	Average weight per m ² : 5,29 kg	9 mm	18 mm

